



---

Colorado Department  
of Public Health  
and Environment

**DEPARTMENT OF PUBLIC HEALTH AND ENVIRONMENT**  
**Consumer Protection Division**  
**6 CCR 1010-2**  
**STATE BOARD OF HEALTH**  
**COLORADO RETAIL FOOD ESTABLISHMENT RULES AND REGULATIONS**

**Last amended March 15, 2006, effective May 30, 2006 –**  
**Section 1-202, Definitions – new definition of “Private Boarding Houses**  
**Note: Section 3-301, Preventing Contamination from Hands, was amended**  
**February 15, 2006, effective March 1, 2007**

# TABLE OF CONTENTS

<b>CHAPTER 1</b> .....	<b>1</b>
<b>PURPOSE AND DEFINITIONS</b> .....	<b>1</b>
1-201 Purpose .....	1
1-202 Definitions .....	1
<b>CHAPTER 2</b> .....	<b>10</b>
<b>MANAGEMENT AND PERSONNEL</b> .....	<b>10</b>
<b>2-1 SUPERVISION</b> .....	<b>10</b>
2-101 Responsibilities .....	10
2-102 * Demonstration.....	10
2-103 * Person in Charge .....	11
<b>2-2 EMPLOYEE HEALTH</b> .....	<b>12</b>
2-201 * Restrictions Regarding Ill Or Otherwise Infected Employees.....	12
2-202 * Reporting .....	12
2-203 * Exclusions.....	12
2-204 * Removal of Exclusions .....	12
2-205 * Restrictions .....	12
2-206 Discharges from the Eyes, Nose and Mouth* .....	13
<b>2-3 AUTHORIZED PERSONNEL</b> .....	<b>13</b>
<b>2-4 PERSONAL CLEANLINESS</b> .....	<b>13</b>
2-402 * When to Wash.....	13
2-403 * Hand Sanitizers .....	14
2-404 * Where to Wash.....	14
2-405 * Fingernail Care .....	14
2-406 Clothing .....	14

2-407 *	Jewelry .....	14
2-408	Dressing Rooms and Locker Areas.....	15
<b>2-5</b>	<b>HYGIENIC PRACTICES .....</b>	<b>15</b>
2-501 *	General.....	15
2-502 *	Eating, Drinking, or Using Tobacco .....	15
2-503	Hair Restraints .....	15
<b>CHAPTER 3</b>	<b>.....</b>	<b>16</b>
<b>FOOD</b>	<b>.....</b>	<b>16</b>
<b>3-1</b>	<b>CHARACTERISTICS .....</b>	<b>16</b>
3-101 *	General.....	16
3-102	Fish and Shellfish.....	16
<b>3-2</b>	<b>SOURCES AND SPECIFICATIONS.....</b>	<b>17</b>
3-201 *	Hermetically Sealed Food.....	17
3-202 *	Dry Milk and Dry Milk Products.....	17
3-203 *	Reconstitution of Dry Milk, Dry Milk Products & Non-Dairy Products	17
3-204 *	Fluid Milk, Fluid Milk Products, and Frozen Dessert Mix.....	17
3-205 *	Wild Mushrooms .....	17
3-206 *	Game Animals and Exotic Species .....	18
3-207 *	Eggs .....	18
3-208	Ice .....	18
3-209 *	Ice Used as Exterior Coolant, Prohibited as Ingredient .....	18
3-210	Storage or Display of Food in Contact With Water or Ice.....	18
3-211 *	Juice .....	18
3-301 *	Preventing Contamination from Hands .....	19
3-302	General.....	21
3-303 *	Cross-Contamination Control .....	21
3-304 *	Pasteurized Eggs, Substitute for Shell Eggs for Certain Recipes .....	21
3-305 *	Washing Fruits and Vegetables/Additives.....	21
3-306	In-Use Utensils, Between Use Storage .....	22

3-307	Wiping Cloths .....	22
3-308	Re-Use of Tableware .....	22
3-309	Refilling Returnables .....	23
3-310	Food Storage.....	23
3-311	Food Storage, Prohibited Areas .....	23
3-312	Food Display.....	24
3-313	Condiments, Protection.....	24
3-314 *	Consumer Self-Service Operations.....	24
3-315 *	Reservice.....	24
<b>3-4 DESTRUCTION OF ORGANISMS OF PUBLIC HEALTH CONCERN.....</b>		<b>24</b>
3-401 *	Temperature .....	24
3-402 *	Cooking Potentially Hazardous Foods.....	25
3-403 *	Reheating .....	25
<b>3-5 LIMITATION OF GROWTH OF ORGANISMS OF PUBLIC HEALTH CONCERN.....</b>		<b>26</b>
3-501	Thawing .....	26
3-502 *	Cooling .....	26
3-503	Cooling Methods.....	27
3-504 *	Time as a Public Health Control.....	27
3-505 *	Modified Atmosphere Packaging, Criteria .....	28
<b>3-6 ON-PREMISES LABELING .....</b>		<b>29</b>
3-601	Labeling .....	29
<b>CHAPTER 4.....</b>		<b>30</b>
<b>WAREWASHING, EQUIPMENT, UTENSILS, AND LINENS.....</b>		<b>30</b>
<b>4-1 MATERIALS FOR CONSTRUCTION AND REPAIR.....</b>		<b>30</b>
4-101	General.....	30
4-102	Equipment Requirements.....	30

<b>4-2 DESIGN AND CONSTRUCTION .....</b>	<b>30</b>
4-201 Food Contact Surfaces .....	30
4-202 Use Limitations .....	31
4-203 Nonfood-Contact Surfaces.....	32
4-204 Clean In Place (CIP) Equipment.....	33
4-205 “V” Threads, Use Limitation .....	33
4-206 Hot-Oil Filtering Equipment.....	33
4-207 Bearings and Gear Boxes, Leakproof .....	33
4-208 Beverage Tubing, Separation.....	33
4-209 Ice Units, Separation of Drains.....	33
4-210 Condenser Unit, Separation .....	33
4-211 * Molluscan Shellfish Tanks.....	34
4-212 Ventilation and Ventilation Hood Systems.....	34
<b>4-3 LOCATION AND INSTALLATION.....</b>	<b>34</b>
4-301 Equipment, and Storage Cabinets, Contamination Prevention .....	34
4-302 Fixed Equipment, Spacing or Sealing.....	35
<b>4-4 TESTING DEVICES - CLEANING FACILITIES.....</b>	<b>38</b>
4-401 Thermometers .....	38
4-402 Sanitizing Solutions, Testing Devices .....	38
4-403 Equipment and Utensil Cleaning and Sanitization .....	38
4-404 Food Establishments Without Cleaning Facilities .....	45
4-405 Food-Contact Surfaces of Equipment and Utensils .....	45
Cleaning Frequency for Continuous Use Equipment .....	45
4-406 Nonfood-Contact Surfaces.....	46
4-407 Dry Equipment Cleaning Methods .....	46
<b>4-5 LAUNDRY FACILITIES .....</b>	<b>46</b>
4-501 Laundry Facilities .....	46
<b>4-6 EQUIPMENT AND UTENSIL HANDLING AND STORAGE .....</b>	<b>46</b>
4-601 Equipment and Utensil Storage .....	46

4-602	Single-Service and Single-Use Articles.....	47
4-603	Preset Tableware.....	47
<b>CHAPTER 5</b>	<b>.....</b>	<b>48</b>
<b>WATER, PLUMBING, AND WASTE</b>	<b>.....</b>	<b>48</b>
<b>5-1 WATER SUPPLY</b>	<b>.....</b>	<b>48</b>
5-101 *	General.....	48
5-102 *	System Flushing and Disinfection.....	48
5-103 *	Bottled Drinking Water.....	48
5-104 *	Transportation.....	48
5-105 *	Non-Potable Water.....	48
5-106 *	Pressure and Temperature.....	49
5-107 *	Hot Water.....	49
5-108 *	Steam.....	49
<b>5-2 PLUMBING SYSTEM</b>	<b>.....</b>	<b>49</b>
5-201	General.....	49
5-202 *	Backflow.....	49
5-203	Conditioning Device, Design.....	50
5-204	Grease Trap / Grease Interceptor.....	50
5-205	Garbage Grinders.....	50
5-206 *	Drainage Of Equipment.....	50
5-207	Drainage System Installation.....	51
5-208	Handwashing Lavatory, Water Temperature, and Flow.....	52
5-209	Toilets and Urinals.....	52
5-210	Utility Facility.....	53
5-211 *	Sewage.....	53
5-212 *	Water Reservoir of Fogging Devices, Cleaning.....	53
<b>5-3 REFUSE, RECYCLABLES, AND RETURNABLES</b>	<b>.....</b>	<b>54</b>
5-301	Containers.....	54
5-302	Storage.....	54

5-303	Disposal .....	55
5-304	Storage Areas, Redeeming Machines, Equipment and Receptacles Location .....	55
<b>CHAPTER 6.....</b>		<b>56</b>
<b>PHYSICAL FACILITIES.....</b>		<b>56</b>
<b>6-1 FLOORS .....</b>		<b>56</b>
6-101	Floor Construction.....	56
6-102	Floor Carpeting.....	56
6-103	Utility Line Installation.....	56
6-104	Floor Junctures.....	56
6-105	Prohibited Floor Covering.....	56
6-106	Mats and Duckboards .....	57
<b>6-2 WALLS AND CEILINGS .....</b>		<b>57</b>
6-201	Construction.....	57
6-202	Attachments, Exposed Construction.....	57
<b>6-3 LIGHTING .....</b>		<b>57</b>
6-301	Light Intensity.....	57
6-302	Light Bulbs, Protective Shielding.....	58
<b>6-4 OPERATION AND MAINTENANCE.....</b>		<b>58</b>
6-401	Cleaning Physical Facilities.....	58
6-402	Cleaning Equipment Storage.....	58
<b>6-5 PREMISES .....</b>		<b>59</b>
6-501	General.....	59
6-502	Living Areas .....	59
<b>CHAPTER 7.....</b>		<b>60</b>
<b>POISONOUS OR TOXIC MATERIALS.....</b>		<b>60</b>

<b>7-1 LABELING AND IDENTIFICATION .....</b>	<b>60</b>
7-101 * Identifying Information, Prominence.....	60
7-102 * Name.....	60
7-103 * Separation .....	60
7-104 * Restriction.....	60
7-105 * Use of Materials.....	60
7-106 * Food Containers.....	61
7-107 * Chemicals for Washing Fruits and Vegetables, Criteria.....	61
7-108 * Boiler Water Additives, Criteria.....	61
7-109 * Drying Agents, Criteria.....	61
7-110 * Personal Medications.....	61
7-111 * First Aid Supplies .....	61
 <b>CHAPTER 8.....</b>	 <b>62</b>
<b>INSECT, RODENT AND ANIMAL CONTROL .....</b>	<b>62</b>
<b>8-1 PREVENTION .....</b>	<b>62</b>
8-101 Outer Openings, Protected.....	62
8-102 * Controlling Pests.....	62
8-103 Insect Control Devices, Design and Installation.....	62
8-104 * Pesticide Application.....	63
8-105 * Removing Birds, Insects, Rodents, and Other Pests.....	63
8-106 * Prohibiting of Animals.....	63
 <b>CHAPTER 9.....</b>	 <b>65</b>
<b>MOBILE RETAIL FOOD ESTABLISHMENTS OR PUSHCARTS .....</b>	<b>65</b>
<b>9-1 MOBILE RETAIL FOOD ESTABLISHMENT .....</b>	<b>65</b>
9-101 General.....	65
9-102 Exemptions .....	65
9-103 Single-service Articles.....	65
9-104 * Water System.....	65

9-105	Wastewater Retention .....	66
9-106 *	Handwashing Facilities .....	66
9-107 *	Commissary .....	67
9-108	Additional Requirements .....	68
<b>CHAPTER 10.....</b>		<b>69</b>
<b>TEMPORARY RETAIL FOOD ESTABLISHMENTS.....</b>		<b>69</b>
<b>10-1</b>	<b>TEMPORARY RETAIL FOOD ESTABLISHMENTS.....</b>	<b>69</b>
10-101	General.....	69
10-102 *	Restricted Operations.....	69
10-103 *	Ice .....	69
10-104	Equipment.....	69
10-105	Single-Service Articles .....	69
10-106 *	Water.....	70
10-107	Wet Storage .....	70
10-108 *	Waste .....	70
10-109	Handwashing .....	70
10-110	Floors .....	70
10-111	Walls and Ceilings.....	70
<b>CHAPTER 11.....</b>		<b>71</b>
<b>COMPLIANCE PROCEDURES .....</b>		<b>71</b>
<b>11-1</b>	<b>COMPLIANCE.....</b>	<b>71</b>
11-101	General.....	71
11-102	Issuance of License or Certificate of License.....	71
11-103	License Renewal.....	71
11-104	Judicial Review.....	71
11-105	Closure Without Suspension.....	72
11-106	Injunctive Relief.....	72
<b>11-2</b>	<b>INSPECTIONS .....</b>	<b>72</b>

11-201	Inspection Frequency.....	72
11-202	Access.....	72
11-203	Report of Inspections.....	73
11-204	Correction of Violations.....	73
11-205	Inspection Report.....	74
<b>11-3</b>	<b>EMBARGO AND CONDEMNATION OF FOOD.....</b>	<b>76</b>
11-301	General.....	76
11-302	Voluntary Condemnation.....	76
11-303	Embargo Placement.....	77
11-304	Embargo Release.....	77
11-305	Condemnation of Product.....	77
<b>11-4</b>	<b>REVIEW OF PLANS.....</b>	<b>77</b>
11-401	Submission of Plans.....	77
11-402	Contents of Plans and Specifications.....	78
11-403	Pre-Operational Inspection.....	78
<b>11-5</b>	<b>PROCEDURE WHEN INFECTION IS SUSPECTED.....</b>	<b>78</b>
11-501	General.....	78
<b>11-6</b>	<b>VARIANCE PROCEDURE.....</b>	<b>78</b>
11-601	Variance Procedure.....	78
<b>11-7</b>	<b>REFERENCE CITATIONS.....</b>	<b>79</b>
11-701	General.....	79
11-702	Safe Materials.....	80
11-703	Food Protection Act.....	80
11-704	Milk Standards.....	80
11-705	Ventilation Requirements.....	80
11-706	Code of Federal Regulations.....	80
11-707	Plumbing Requirements.....	80
11-708	Administrative Statutes.....	80

11-709 American National Standards Institute (ANSI) ..... 81

## **APPENDICES**

*Appendix A - Potentially Hazardous Foods*..... A 1-2  
*Appendix B – Safe Materials Colorado Pure Food and Drug Law*..... B 1  
*Appendix C – Plan Review*..... C 1-13  
*Appendix D – Worksheet for Calculating Minimum Hot Water Requirements* ..... D 1-4  
*Appendix E – Specific Usage Additives* ..... E 1-4  
*Appendix F – Lubricants*..... F 1-4  
*Appendix G – Sanitizers*..... G 1  
*Appendix H – HACCP Guidelines* .....H 1-30  
*Appendix I – Retail Food Sanitation Act (Bulk Food Law)* ..... I 1-4  
*Appendix J – Equipment Investigation Report*..... J 1-3

## CHAPTER 1

### PURPOSE AND DEFINITIONS

#### 1-201 Purpose

The following rules and regulations shall be applied for the protection of public health.

#### 1-202 Definitions

The following terms are defined for the purposes of the rules and regulations.

- (1) **“Asterisk”(\*)** means any section denoted with an \* indicates it is a critical item.
- (2) **“Adulterated”** means as stated in the Colorado Pure Food and Drug Act, section 25-5-4, C.R.S.
- (3) **“Approved”** means acceptable to the Department, or its authorized agents, and employees based on determination of conformance with applicable, documented standards and good public health practices.
- (4) **“Bulk Foods”** means foods as defined in section 25-4-1302, C.R.S.
- (5) **“Clean In Place (CIP)”** means cleaned in place by the circulation or flowing by mechanical means through a piping system of a detergent solution, water rinse, and sanitizing solution onto or over equipment surfaces that require cleaning, such as the method used, in part, to clean and sanitize a frozen dessert machine.  

CIP does not include the cleaning of equipment such as band saws, slicers or mixers that are subjected to in-place manual cleaning without the use of a CIP system.
- (6) **“Commercial Design”** means all equipment meeting recognized commercial sanitation criteria by organizations, such as the National Sanitation Foundation (NSF), Underwriters Laboratories (UL) sanitation standards, Environmental Testing Laboratories, Inc. (ETL) sanitation standards, Baking Industry Sanitation Standards Committee (BISSC), or other comparable design criteria as approved by the Department during a standardized equipment review.
- (7) **“Comminuted”** means reduced in size by methods including chopping, flaking, grinding, or mincing. This includes fish or meat products that are reduced in size and restructured or reformulated such as gefilte fish, formed roast beef, gyros, ground beef, and sausage; and a mixture of two or more types of meat which have been reduced in size and combined, such as sausages made from two or more meats.
- (8) **“Commissary”** means an approved catering establishment, restaurant, or other approved place in which food, containers, or supplies are kept, handled, prepared, packaged or stored.
- (9) **“Contamination”** means to make unfit for use by the introduction or potential introduction of unwholesome or undesirable elements.

- (10) **“Corrosion-Resistant Materials”** means those materials which maintain their original surface characteristics under prolonged contact with food, the normal use of cleaning compounds and bactericidal solutions, and other conditions of use.
- (11) **“Critical Control Point”** means any point in a food preparation process at which loss of control might result in an unacceptable consumer health risk.
- (12) **“Critical Item”** means a provision of these rules and regulations that, if in noncompliance, is more likely than other violations to contribute to food contamination, illness, or environmental degradation. These are items denoted in these rules and regulations with an asterisk \*.
- (13) **“Department”** means Colorado Department of Public Health and Environment, or its authorized agents, and employees.
- (14) **“Dry Storage Area”** means a room or area used for the storage of non potentially hazardous packaged or containerized food and dry goods such as single-service items.
- (15) **“Easily Cleanable”** means surfaces are readily accessible and fabricated of such materials and finishes that residue can be effectively removed by normal cleaning methods.
- (16) **“Employee”** means any person working in a food establishment who transports food or food containers, who engages in food preparation or service, or who comes in contact with any food, utensils or equipment.
- (17) **“Equipment”** means an article used in the operation of a food establishment, such as, but not limited to a freezer, grinder, hood, ice maker, meat block, mixer, oven, reach-in refrigerator, range, scale, sink, slicer, stove, table, thermometer, or warewashing machine.

Equipment does not include items used for handling or storing large quantities of packaged foods received from a supplier in a cased or overwrapped lot, such as hand trucks, forklifts, dollies, pallets, racks, and skids.

- (18) **“Extensively Remodeled”** means any major alteration of an existing configuration in a food establishment which might affect the food operation that results in one or more of the following conditions:
  - A. Seating capacity, including service provided anywhere on the premises, is increased by 20 percent or more in either a single construction project or an incremental series of construction activities;
  - B. Alterations or revisions involving retail food establishments or related equipment that require a building or construction permit by local building authorities. Routine maintenance, repairs or cosmetic changes shall not be defined as extensive remodeling;
  - C. Changes or alterations made in the nonpublic areas that result in a reduction or increase of total space by 25 percent or more; or
  - D. The facility's capabilities to handle food and utensils in a sanitary manner have been diminished, creating potentially hazardous conditions.

- (19) **“Fish”** means fresh or saltwater finfish, crustaceans, and other forms of aquatic animal life (including, but not limited to alligator, frog, aquatic turtle, jellyfish, sea cucumber, and sea urchin and the roe of such animals) other than birds or mammals, and includes any edible human food product derived in whole or in part from fish, including fish that has been processed in any manner.
- (20) **“Food”** means a raw, cooked, or processed edible substance, ice, beverage, or ingredient used or intended for use or for sale in whole or in part for human consumption.
- (21) **“Foodborne Disease Outbreak”** means:
- A. An incident, except as specified in subparagraph (b) of this definition, in which:
    - 1. Two or more otherwise unrelated persons experience a similar illness after ingestion of a common food; and
    - 2. Epidemiological analysis implicates the food as the source of the illness.
  - B. Includes a single case of illness, such as one person ill from botulism or chemical poisoning.
- (22) **“Food-Contact Surfaces”** means those surfaces of equipment and utensils with which food normally comes in contact, and those surfaces from which food may drain, drip, or splash back onto surfaces in contact with food. This excludes ventilation hoods.
- (23) **“Food Processing Establishment”** means an establishment in which food is processed, prepared, packaged, and distributed for human consumption and approved by the Department. This term does not include a retail food establishment, or commissary operation.
- (24) **“Game Animal”** means an animal, the products of which are food, that is not classified as domestic cattle, sheep, swine, goat, or poultry, or fish.
- “Game Animal”** includes:
- Animals, such as reindeer, elk, deer, antelope, bison, rabbit, squirrel, bear, and muskrat; nonaquatic reptiles, such as rattlesnakes; aquatic mammals; and exotic animals, such as lion, tiger, leopard, elephant, camel, antelope, anteater, kangaroo, water buffalo, species of foreign domestic cattle, such as Ankole, Gaya, Yak , and other animals approved by the Department.
- “Game Animal”** does not include:
- Ratites such as ostrich, emu, and rhea.
- (25) **“Ground Beef”** means meat that is derived from the voluntary striated muscle of beef, with a maximum of thirty percent total fat by weight, with no water, phosphates, extenders, or binders added.
- (26) **“HACCP Plan”** means a written document that delineates the formal procedures for following the Hazard Analysis Critical Control Point principles.
- (27) **“Hazard”** means a biological, chemical, or physical property that might cause an unacceptable consumer health risk.

- (28) **“Hermetically Sealed Container”** means a container designed and intended to be secure against the entry of microorganisms and to maintain the commercial sterility of its content after processing.
- (29) **“Highly Susceptible Population”** means persons who are more likely than other people in the general population to experience foodborne disease because they are immunocompromised, preschool age children, or older adults; and they obtain food at a facility that provides services such as custodial care, health care, or assisted living, such as a child or adult day care center, kidney dialysis center, hospital or nursing home, or nutritional or socialization services such as a senior center.
- (30) **“Hygroscopic”** means readily taking up and retaining moisture.
- (31) **“Imminent Health Hazard”** means a significant threat or danger to health that is considered to exist when there is evidence sufficient to show that a product, practice, circumstance, or event creates a situation that requires immediate correction or cessation of operation to prevent injury or illness based on:
- A. The number of potential injuries or illnesses, and
  - B. The nature, severity, and duration of the anticipated injury or illness.
- (32) **“Kitchenware”** means all multi-use utensils other than tableware, used in the storage, preparation, transportation or serving of food.
- (33) **“Law”** means applicable local, state, and federal statutes, regulations, and ordinances.
- (34) **“Linens”** means fabric items such as cloth hampers, cloth napkins, tablecloths, wiping cloths, and work garments including cloth gloves.
- (35) **“Meat”** means the flesh of animals used as food including the dressed flesh of cattle, swine, sheep, or goats and other edible animals, except fish, poultry, and wild game animals.
- (36) **“mg/L”** means milligrams per liter, which is the metric equivalent of parts per million (ppm).
- (37) **“Mobile Retail Food Establishment”** means a retail food establishment that reports to and operates from a commissary and is readily moveable, is a motorized wheeled vehicle, or a towed wheeled vehicle designed and equipped to serve food.
- (38) **“Modified Atmosphere Packaging”** means the reduction of the amount of oxygen in a package by mechanically evacuating the oxygen; displacing the oxygen with another gas or combination of gases; or otherwise controlling the oxygen content in a package to a level below what is normally found in the surrounding atmosphere, which is 21% oxygen. Reduced oxygen packaging includes methods that may be referred to as altered atmosphere, modified atmosphere, controlled atmosphere, low oxygen, and vacuum packaging including sous vide.
- (39) **“Molluscan Shellfish”** means any edible species of fresh or frozen oysters, clams, mussels, and scallops or edible portions thereof, except when the scallop product consists only of the shucked adductor muscle.
- (40) **“Nonfood-Contact Surfaces”** means all surfaces other than food-contact surfaces.

- (41) **“Packaged”**
- A. Means bottled, canned, cartoned, securely bagged, or securely wrapped, whether packaged in a food establishment or a food processing plant.
  - B. “Packaged” does not include a wrapper, carry-out box, or other nondurable container used to containerize food with the purpose of facilitating food protection during service and receipt of the food by the consumer.
- (42) **“Person”** means a natural person, partnership, association, company, corporation, organization, or manager, agent, servant officer, or employee of any of them or other legal entity.
- (43) **“Person In Charge”** means the individual present at a retail food establishment who is responsible for the operation at the time of inspection. If no individual is responsible, then any employed person present is the person in charge.
- (44) **“Personal Care Items”** means items or substances that may be poisonous, toxic, or a source of contamination which are used to maintain or enhance a person's health, hygiene, or appearance, such as medicines, first aid supplies, cosmetics, toiletries, toothpaste and mouthwash.
- (45) **“pH”** means the measure of the degree of acidity or alkalinity of a solution. Values between 0 and 7 indicate acidity and values between 7 and 14 indicate alkalinity. The value for pure distilled water is 7, which is considered neutral.
- (46) **“Physical Facilities”** means the structure and interior surfaces of a retail food establishment including attachments, such as light fixtures and heating or air conditioning system vents.
- (47) **“Poisonous or Toxic Materials”** means substances not intended for ingestion and are included in four categories:
- A. Cleaners and sanitizers, which include cleaning and sanitizing agents and agents such as caustics, acids, drying agents, polishes, and other chemicals;
  - B. Pesticides, which include substances such as insecticides and rodenticides;
  - C. Substances necessary for the operation and maintenance of the establishment such as nonfood grade lubricants and personal care items that may be deleterious to health; and
  - D. Substances that are not necessary for the operation and maintenance of the establishment and are on the premises for retail sale, such as petroleum products and paints.
- (48) **“Potentially Hazardous Food”** means a food that is natural or synthetic and that requires temperature control because it is in a form capable of supporting:
- A. The rapid and progressive growth of infectious or toxigenic microorganisms;
  - B. The growth and toxin production of *Clostridium botulinum*: or
  - C. In raw shell eggs, the growth of *Salmonella enteritidis*.

- (i) **“Potentially Hazardous Food”** includes a food of animal origin that is raw or heat-treated; a food of plant origin that is heat-treated or consists of raw seed sprouts; cut melons; and garlic in oil mixtures that are not acidified or otherwise modified at a food processing plant in a way that results in mixtures that do not support growth as specified in subparagraphs 1, 2 and 3 of this definition.
- (ii). **“Nonpotentially Hazardous Food”** includes:
  - a. Hard-boiled eggs with shells intact which have been air cooled;
  - b. Foods with a water activity ( $a_w$ ) value of 0.85 or less;
  - c. Foods with a measurement of acidity (pH) of 4.6 or below;
  - d. Foods which have been adequately commercially processed and remain in their unopened hermetically-sealed container; and
  - e. Food for which laboratory evidence (acceptable to the regulatory authority) demonstrates that rapid and progressive growth of infectious and toxigenic microorganisms, the growth of *S. enteritidis* in eggs or the slower growth of *Clostridium botulinum* cannot occur.
- (49) **“Poultry”** means any domesticated bird such as chickens, turkeys, ducks, geese, or guineas and any migratory waterfowl, game bird, such as pheasant, partridge, quail, grouse, or guinea, or pigeon, or squab.
- (50) **“Premises”** means the physical facility, its contents, and the contiguous land or property and its facilities and contents that may impact retail food establishment personnel, facilities, or operations.
- (51) **“Primal Meat Cuts”** means any of various wholesale cuts into which a carcass of a food animal is divided.
- (52) **“Private Boarding Houses”** means a house at which meals, or meals and lodging, may be obtained for payment."
 

"Private Boarding Houses" does not include:

  - A. Hotels
  - B. Motels
  - C. Homeless shelters
  - D. Youth hostel
  - E. Other commercial facilities providing lodging and/or meals for the indigent population whether or not there is a charge for such food and/or lodging.
- (53) **“Pushcart”** means a non-self-propelled vehicle limited to serving commissary prepared or prepackaged food and non-potentially hazardous food unless the equipment is commercially designed and approved to handle food preparation and service.
- (54) **“Ready-to-Eat Food”** means food that is edible without further washing, cooking, or additional preparation and that is reasonably expected to be consumed in that form.

- (55) **“Reconstituted”** means dehydrated food products recombined with water or other liquids.
- (56) **“Retail Food Establishment”** means a retail operation that stores, prepares, or packages food for human consumption or serves or otherwise provides food for human consumption to consumers directly or indirectly through a delivery service, whether such food is consumed on or off the premises or whether there is a charge for such food.

**“Retail Food Establishment”** does not include:

- A. Any private home;
- B. Private boarding houses;
- C. Hospital and health facility patient feeding operations licensed by the Department;
- D. Child care centers and other child care facilities licensed by the Department of human services;
- E. Hunting camps and other outdoor recreation locations where food is prepared in the field rather than at a fixed base of operation;
- F. Food or beverage wholesale manufacturing, processing, or packaging plants, or portions thereof, that are subject to regulatory controls under state or federal laws or regulations;
- G. Motor vehicles used only for the transport of food;
- H. Establishments preparing and serving only hot coffee, hot tea, instant hot beverages, and nonpotentially hazardous doughnuts or pastries obtained from sources complying with all laws related to food and food labeling;
- I. Establishments that handle only nonpotentially hazardous prepackaged food and operations serving only commercially prepared, prepackaged foods requiring no preparation other than the heating of food within its original container or package;
- J. Farmers markets and roadside markets that offer only uncut fresh fruit and vegetables for sale;
- K. Automated food merchandising enterprises that supply only prepackaged nonpotentially hazardous food or drink or food or drink in bottles, cans, or cartons only, and operations that dispense only chewing gum or salted nuts in their natural protective covering;
- L. The donation, preparation, sale, or service of food by a nonprofit or charitable organization in conjunction with an event or celebration if such donation, preparation, sale, or service of food;
  - 1. Does not exceed the duration of the event or celebration or a maximum of fifty-two days within a calendar year; and
  - 2. Takes place in the county in which such nonprofit or charitable organization resides or is principally located.

- (57) **“Safe Materials”** means articles manufactured from or composed of materials that may not reasonably be expected to result, directly or indirectly, in their becoming a component or otherwise affecting the characteristic of any food. If materials are food additives or color additives as defined in section 25-5-402(3) or (12), C.R.S., of the “Colorado Pure Food and Drug Law”, as used, they are “safe” only if they are used in conformity with all applicable regulations of the U.S. Food and Drug Administration.
- (58) **“Sanitization”** means the application of cumulative heat or chemicals on cleaned food-contact surfaces that, when evaluated for efficacy, is sufficient to yield a reduction of 5 logs, which is equal to a 99.999% reduction, of representative disease microorganisms of public health importance.
- (59) **“Shellstock”** means raw, in-shell, molluscan shellfish.
- (60) **“Shucked Shellfish”** means molluscan shellfish that have one or both shells removed.
- (61) **“Single-Service Articles”** means cups, containers, lids, closures, plates, knives, forks, spoons, stirrers, paddles, straws, napkins, place mats, doilies, wrapping materials, toothpicks and similar articles intended for one-time, one-person use and then discarded after use.
- (62) **“Single-Use Articles”** means utensils and bulk food containers designed and constructed to be used once and discarded.
- (63) **“Smooth”** means:
- A. A food-contact surface having a surface free of pits and inclusions with a cleanability equal to or exceeding that of (100 grit) number 3 stainless steel;
  - B. A nonfood-contact surface of equipment having a surface equal to that of commercial grade hot-rolled steel free of visible scale; and
  - C. A floor, wall, or ceiling having an even or level surface with no roughness, projections, perforations, pits, or inclusions that render it difficult to clean.
- (64) **“Subprimal Meat Cuts”** means cuts made in the retail food establishment from primal meat cuts.
- (65) **“Support Animal”** means a trained animal, such as a guide or service animal, that accompanies a person with a disability to assist in managing the disability and enables the person to perform functions that the person would otherwise be unable to perform.
- (66) **“Tableware”** means eating, drinking, and serving utensils for table use, such as forks, knives, and spoons; including bowls, cups, serving dishes, tumblers and plates.
- (67) **“Temporary Retail Food Establishment”** means a food establishment that operates at a fixed location for a period of time of not more than fourteen (14) consecutive days in conjunction with a single event or celebration.
- (68) **“Utensil”** means any implement used in the storage, preparation, transportation, or service of food.
- (69) **“Warewashing”** means the cleaning and sanitizing of equipment and utensil food-contact surfaces.

(70) **“Water Activity”** ( $a_w$ ) means a measure of free moisture in a food and is indicated by the symbol  $a_w$ .

## **CHAPTER 2**

### **MANAGEMENT AND PERSONNEL**

#### **2-1 SUPERVISION**

##### **2-101 Responsibilities**

The operator shall be the person in charge or shall designate a person in charge and shall ensure that a person in charge is present at the retail food establishment during all hours of operation. \*The operator shall educate and monitor employees to ensure conformance to these rules and regulations.

##### **\*2-102 Demonstration**

Based on the risks of foodborne illness inherent to the food operation, during inspections and upon request the person in charge shall demonstrate to the regulatory authority knowledge of foodborne disease prevention, application of the Hazard Analysis Critical Control Point principles, and the requirements of these rules and regulations. The person in charge shall demonstrate this knowledge by:

- A. Complying with these rules and regulations; or
- B. Being a certified food protection manager who has shown proficiency of required information through passing a test that is part of an accredited program; or
- C. Responding correctly to the inspector's questions as they relate to the specific food operation. The areas of knowledge include:
  - (1) Describing the relationship between the prevention of foodborne disease and the personal hygiene of a food employee;
  - (2) Explaining the responsibility of the person in charge for preventing the transmission of foodborne disease by a food employee who has a disease or medical condition that may cause foodborne disease;
  - (3) Describing the symptoms associated with the diseases that are transmissible through food;
  - (4) Explaining the hazards involved in the consumption of raw or undercooked meat, poultry, eggs and fish;
  - (5) Stating the required temperatures and times for the safe cooking, refrigerated storage, hot holding, cooling, and reheating of potentially hazardous food;
  - (6) Describing the relationship between the prevention of foodborne illness and the management and control of the following:
    - (a) Cross contamination,
    - (b) Hand contact with ready-to-eat foods,
    - (c) Handwashing, and

- (d) Maintaining the food establishment in a clean condition and in good repair;
- (7) Explaining the relationship between food safety and providing equipment that is:
  - (a) Sufficient in number and capacity, and
  - (b) Properly designed, constructed, located, installed, operated, maintained, and cleaned;
- (8) Explaining correct procedures for cleaning and sanitizing utensils and food-contact surfaces of equipment;
- (9) Identifying the source of water used and measures taken to ensure that it remains protected from contamination such as providing protection from backflow and precluding the creation of cross connections;
- (10) Identifying poisonous or toxic materials in the food establishment and the procedures necessary to ensure that they are safely stored, dispensed, used, and disposed of according to law;
- (11) Identifying critical control points in the operation from purchasing through sale or service that when not controlled may contribute to the transmission of foodborne illness and explaining steps taken to ensure that the points are controlled in accordance with the requirements of these rules and regulations.

**\*2-103 Person in Charge**

The person in charge shall ensure that:

- A. Employees are effectively cleaning their hands, by routinely monitoring the employees' handwashing;
- B. Employees are visibly observing foods as they are received to determine that they are from approved sources, delivered at the required temperatures, protected from contamination, unadulterated, and accurately presented, by routinely monitoring the employees' observations and periodically evaluating foods upon their receipt;
- C. Employees are properly cooking potentially hazardous food, being particularly careful in cooking those foods known to cause severe foodborne illness and death, such as eggs and comminuted meats, through daily oversight of the employees' routine monitoring of the cooking temperatures using appropriate temperature measuring devices properly scaled and calibrated as specified under §4-401;
- D. Employees are using proper methods to rapidly cool potentially hazardous foods that are not held hot or are not for consumption within 4 hours, through daily oversight of the employees' routine monitoring of food temperatures during cooling;
- E. Employees are properly sanitizing cleaned multiuse equipment and utensils before they are reused, through routine monitoring of solution temperature and exposure time for hot water sanitizing, and chemical concentration, pH, temperature, and exposure time for chemical sanitizing;
- F. Consumers are notified that clean tableware is to be used when they return to self-service areas such as salad bars and buffets as specified under §3-308;

- G. Employees are minimizing bare hand contact with ready-to-eat food by properly using suitable utensils such as deli tissue, spatulas, tongs, single-use gloves, or dispensing equipment; and
- H. Employees are properly trained in food safety as it relates to their assigned duties.

## **2-2 EMPLOYEE HEALTH**

### **\*2-201 Restrictions Regarding Ill Or Otherwise Infected Employees**

No employee, while infected with a communicable disease that can be transmitted by foods or who is a carrier of organisms that cause such a disease or while afflicted with a boil, an infected wound on an exposed body part, or an acute respiratory infection, shall work in a retail food establishment in any capacity in which there is a likelihood of such employee contaminating food or food-contact surfaces with pathogenic organisms or transmitting disease to other persons.

### **\*2-202 Reporting**

It shall be the responsibility of the employee to report to the person in charge when infected with or a carrier of a communicable disease or an organism that may be transmitted by food.

### **\*2-203 Exclusions**

The person in charge shall exclude an employee from a retail food establishment if the employee is diagnosed with an infection where there is a likelihood of such employee contaminating as specified in section 2-201 of these rules and regulations.

### **\*2-204 Removal of Exclusions**

The person in charge may remove an exclusion, applied under section 2-203 of these rules and regulations, with the Department's approval.

### **\*2-205 Restrictions**

Any employee with a pustular lesion, such as a boil or infected wound, on any exposed portions of the body shall keep such lesion covered by a dry, waterproof, durable, tight fitting bandage and a single-use glove, if on the hands or wrist, that shields the wound from direct contact with food or equipment.

## **2-206 Discharges from the Eyes, Nose and Mouth\***

Food employees experiencing persistent sneezing, coughing, or a runny nose that causes discharges from the eyes, nose or mouth may not work with exposed food, clean equipment, utensils, and linens, or unwrapped single-service or single-use articles.

## **2-3 AUTHORIZED PERSONNEL**

Only persons necessary to the operation and maintenance of the retail food establishment shall be allowed in food preparation, food storage, food equipment storage, and warewashing areas.

## **2-4 PERSONAL CLEANLINESS**

### **2-401 Cleaning Procedure**

- A. Food Employees shall clean their hands and exposed portions of their arms for at least 20 seconds and shall use the following cleaning procedure:
  - (1) Vigorous friction on the surfaces of the lathered fingers, finger tips, areas between the fingers, hands and arms for at least 15 seconds, followed by;
  - (2) Thorough rinsing under clean, running warm water; and
  - (3) Immediately follow the cleaning procedure with thorough drying of cleaned hands and arms.
- B. Food employees shall pay particular attention to the areas underneath the fingernails during the cleaning procedure.
- C. If approved and capable of removing the types of soils encountered in the food operations involved, an automatic handwashing facility may be used by food employees to clean their hands.

### **\*2-402 When to Wash**

Food employees shall clean their hands and exposed portions of their arms immediately before engaging in food preparation including working with exposed food, clean equipment and utensils, and unwrapped single-service and single-use articles and:

- A. When returning to the kitchen after using the toilet room;
- B. After coughing, sneezing, using a handkerchief or disposable tissue, using tobacco, eating, or drinking;
- C. When switching between working with raw foods of animal origin and working with ready-to-eat foods;
- D. After touching bare human body parts other than clean hands and clean, exposed portions of arms;
- E. During food preparation, as often as necessary to remove soil and contamination and to prevent cross-contamination when changing tasks;

- F. Before donning single-use gloves for working with food, and between removing soiled gloves and putting on clean gloves;
- G. After handling soiled equipment or utensils;
- H. After caring for or handling any animals;.
- I. After engaging in any activities that contaminate the hands;
- J. After handling fish in aquariums, shellfish, or crustacea in display tanks.

**\*2-403 Hand Sanitizers**

Hand sanitizers may be used in addition to but not in place of proper handwashing.

**\*2-404 Where to Wash**

Food employees shall clean their hands in a handsink or approved automatic handwashing facility and may not clean their hands in a sink used for food preparation or warewashing, or in a utility sink or a curbed cleaning facility used for the disposal of mop water and similar liquid waste.

**\*2-405 Fingernail Care**

- A. Food employees shall keep their fingernails clean, trimmed, filed and maintained so the edges and surfaces are cleanable and not rough.
- B. Unless wearing intact gloves in good repair, a food employee may not wear fingernail polish or artificial fingernails when working with exposed food.
- C. This section does not apply to employees such as counter staff who serve only beverages and wrapped or packaged foods, or hostesses and wait staff who present a minimal risk of contaminating exposed foods, clean equipment, utensils, and linens, and unwrapped single-service and single-use articles.

**2-406 Clothing**

Employees shall wear clean outer clothing to prevent cross-contamination.

**\*2-407 Jewelry**

- A. While preparing food, food employees may not wear jewelry, including medical information jewelry, on their arms and hands. This section does not apply to the wearing of a single ring.
- B. This section does not apply to employees such as counter staff who serve only beverages and wrapped or packaged foods, or hostesses and wait staff who present a minimal risk of contaminating exposed foods, clean equipment, utensils, and linens, and unwrapped single-service and single-use articles.

## **2-408 Dressing Rooms and Locker Areas**

- A. If employees routinely change clothes within a retail food establishment, rooms or areas shall be designated and used for that purpose. These designated rooms or areas shall not be used for food preparation, food storage, food display, warewashing, or storage of utensils and equipment.
- B. Lockers or other suitable facilities shall be provided and used for the orderly storage of employee clothing and other belongings. Lockers or other suitable facilities may only be located in designated dressing rooms or areas, or in food storage rooms or areas containing only completely packaged food or packaged single-service articles.

## **2-5 HYGIENIC PRACTICES**

### **\*2-501 General**

Employees shall maintain a high degree of personal cleanliness and shall conform to good hygienic practices during all working periods.

### **\*2-502 Eating, Drinking, or Using Tobacco**

- A. Except as specified in paragraph B, employees shall consume food, drink or use tobacco only in designated areas. Such designated areas must be located so that eating or tobacco use of an employee does not result in contamination of food, equipment, utensils, or other items needing protection.
- B. An employee may drink from a closed beverage container if:
  - 1. The container is clean;
  - 2. It does not contaminate the employee's hands; and
  - 3. It is stored to prevent the contamination of exposed food, clean equipment, utensils, linens, unwrapped single-service and single-use articles.

### **2-503 Hair Restraints**

- A. Except as provided under paragraph B of this section, employees engaged in food preparation shall wear hair restraints, such as hats, hair coverings, nets, or other effective means, to effectively keep hair from contacting exposed food, clean equipment, utensils, and linens, and unwrapped single-service or single-use articles.
- B. This section does not apply to employees such as counter staff who serve only beverages and wrapped or packaged foods, or hostesses and wait staff who present a minimal risk of contaminating exposed foods, clean equipment, utensils, and linens, and unwrapped single-service and single-use articles.

## CHAPTER 3

### FOOD

#### 3-1 CHARACTERISTICS

##### \*3-101 General

Food shall be in sound condition free from spoilage or contamination and shall be safe for human consumption. Food shall be obtained from approved sources that comply with the applicable laws relating to food and food labeling. Food prepared in a private home shall not be used or offered for sale.

##### 3-102 Fish and Shellfish

\*A. Fresh and frozen shucked molluscan shellfish (oysters, clams, mussels or scallops) shall be received and/or repacked in non-returnable packages identified with the name and address of the original shellstock processor, shucker-packer, or repacker, and the state shellstock certification number issued according to law. Shucked molluscan shellfish shall be kept in the container in which they were received until used or sold.

Each original container of unshucked molluscan shellfish shall be identified by an attached tag, to be retained for a period of 90 days, that states the name and address of the original shellfish processor, the kind and quantity of shellfish, and the certification number issued by the State or foreign shellfish control agency, where applicable.

Shellstock from one tagged or labeled container shall not be commingled with shellstock from another container before being ordered by the consumer.

\*B. Except as specified in paragraph C of this section, before service or sale in ready-to-eat form, raw, raw-marinated, lightly cooked-marinated, marinated, or partially cooked fish other than molluscan shellfish shall be frozen throughout to a temperature of:

1. -4°F (-20°C) or below for 168 hours (7 days) in a freezer; or
2. -31°F (-35°C) or below for 15 hours in a blast freezer.

The freezing temperature and time to which the fish are subjected shall be recorded, retained and made readily available upon request at the food establishment for 90 calendar days after the time of service or sale of the fish.

If the fish are frozen by the retail food establishment and/or supplier, a written agreement or statement from the supplier stipulating that the fish supplied are frozen to the proper temperature and for a time specified in this section may substitute for the records required.

\*C. If the fish are tuna of the species *Thunnus alalunga*, *Thunnus albacares* (Yellowfin tuna), *Thunnus atlanticus*, *Thunnus maccoyii* (Bluefin tuna, Southern), *Thunnus obesus* (Bigeye tuna), or *Thunnus thynnus* (Bluefin tuna, Northern), the fish may be served or sold in a raw, raw-marinated, or partially cooked ready-to-eat form without freezing as specified under paragraph B of this section.

## **3-2 SOURCES AND SPECIFICATIONS**

### **\*3-201 Hermetically Sealed Food**

The use of food from hermetically sealed containers that was not prepared in an approved food processing establishment is prohibited.

Hermetically sealed packages shall be handled so as to maintain product and container integrity. Food items that are spoiled or that are in damaged containers that may affect the product and those food items that have been returned to, or are being detained by, the retail food establishment because of spoilage, container damage, or other public health considerations shall be segregated and held in designated areas pending proper disposition unless disposed of under the supervision of the regulatory authority.

### **\*3-202 Dry Milk and Dry Milk Products**

Dry milk and milk products used, served or offered for sale shall be made from pasteurized milk and milk products.

### **\*3-203 Reconstitution of Dry Milk, Dry Milk Products and Non-Dairy Products**

Dry milk, dry milk products and non-dairy creaming, whitening, or whipping agents may be reconstituted with potable water on the premises only when they will be stored in sanitized, covered containers and cooled to 41°F (7°C) or below within four hours after preparation.

Reconstituted dry milk cannot be substituted for use as a Grade A fluid milk product in its final form (e.g. for drinking, over cereal, etc.).

### **\*3-204 Fluid Milk, Fluid Milk Products, and Frozen Dessert Mix**

Fluid milk and fluid milk products used, served or offered for sale shall comply with the Colorado Grade A Pasteurized Fluid Milk and Milk Products Regulation.

Only pasteurized mix from an approved licensed dairy plant may be mixed and/or frozen by a counter freezer.

### **\*3-205 Wild Mushrooms**

- A. Except as specified in paragraph B of this section, mushroom species picked in the wild shall be obtained from sources where each mushroom is individually inspected and found to be safe by a mushroom identification expert approved by the regulatory agency.
- B. This section does not apply to:
  - 1. Cultivated wild mushroom species that are grown, harvested, and processed in an operation that is regulated by the regulatory agency that has jurisdiction over the operation; or
  - 2. Wild mushroom species if they are in packaged form and are the product of a food processing plant that is regulated by the food regulatory agency that has jurisdiction over the plant.

**\*3-206 Game Animals and Exotic Species**

Game animals and exotic species may be received for sale or service provided they are slaughtered and processed according to laws governing meat and poultry as determined by the agency that has animal health jurisdiction and the agency that conducts the inspection program.

**\*3-207 Eggs**

A. Only clean shell eggs meeting applicable grade standards or pasteurized shell, liquid, frozen or dry eggs, or pasteurized dry egg products shall be used or offered for sale.

**3-208 Ice**

\*A. Source. Only ice which has been manufactured from potable water and handled in a sanitary manner shall be used or offered for sale. Ice offered for sale shall be packaged and properly labeled.

B. Dispensing. Ice for human consumption shall be dispensed only by employees with scoops, tongs, or other ice dispensing utensils, or through automatic self-service, ice dispensing equipment. Ice dispensing utensils shall be stored on a clean surface or in the ice with the dispensing utensil's handle extended out of the ice. Between uses, ice transfer receptacles shall be stored in a way that protects them from contamination.

**\*3-209 Ice Used as Exterior Coolant, Prohibited as Ingredient**

Ice used as a cooling medium for food storage, food containers or food utensils shall not be used or sold for human consumption.

**3-210 Storage or Display of Food in Contact With Water or Ice**

A. Packaged food may be stored in direct contact with potable ice or potable water if the packaging, wrapping, or container is not subject to entry of water.

B. Except as specified in C and D of this section, unpackaged food may not be stored in direct contact with undrained ice.

C. Whole raw fruits and whole or cut raw vegetables, such as celery or carrot sticks or cut potatoes; and tofu may be immersed in potable ice or potable water.

D. Raw chicken and raw fish that are received immersed in potable ice in shipping containers may remain in that condition while in storage awaiting preparation, display, service, or sale.

**\*3-211 Juice**

A. Pre-packaged juice shall be obtained pasteurized; in a sterile shelf-stable form in a hermetically sealed container; or otherwise treated under an approved HACCP plan as specified in 21 CFR §120.24, (2003) to attain a 5-log reduction of the most resistant microorganism of public health significance.

B. Juice packaged in a retail establishment and sold exclusively and directly to its consumers does not have to be processed in conformance with an approved HACCP plan,

but if packaged shall bear the phrase: **“WARNING:** This product has not been pasteurized and, therefore, may contain harmful bacteria that can cause serious illness in children, the elderly, and persons with weakened immune systems” and meet the requirements of the Federal Fair Packaging and Labeling Act.

### **3-3 PROTECTION FROM CONTAMINATION AFTER RECEIVING**

#### **\*3-301 Preventing Contamination from Hands (Effective until March 1, 2007)**

- A. Food shall be prepared with minimal manual contact. This can be achieved by the use of suitable utensils, such as deli tissues, spatulas, tongs, or single-use gloves. Employees shall not contact ready-to-eat foods with their bare hands when it is determined by the Department that no bare hand contact with ready-to-eat food is necessary to control pathogenic microorganisms that are transmissible by food.
- B. If used, single-use gloves shall be used for only one task, such as working with ready-to-eat food, or with raw animal food. Single-use gloves shall be used for no other purpose, and discarded when damaged, soiled, when interruptions occur in the operation, or when the task is completed.

#### **\*3-301 Preventing Contamination from Hands (Effective March 1, 2007)**

- A. **Food employees shall wash their hands as specified under §2-402.**
- B. **Food employees shall minimize bare hand and arm contact with exposed food that is not in a ready-to-eat form.**
- C. **Except when washing fruits and vegetables as specified under §3-305(a) or except as specified in (D) of this section, food employees may not contact exposed, ready-to-eat food with their bare hands and shall use suitable utensils such as deli tissue, spatulas, tongs, single-use gloves, or dispensing equipment.**
- D. **Food employees not serving a highly susceptible population (“Highly Susceptible Population” means persons who are more likely than other people in the general population to experience foodborne disease because they are immunocompromised, preschool age children, or older adults; and they obtain food at a facility that provides services such as custodial care, health care, or assisted living, such as a child or adult day care center, kidney dialysis center, hospital or nursing home, or nutritional or socialization services such as a senior center.) may contact exposed, ready-to-eat food with their bare hands if:**
  - 1. **Written procedures are maintained in the food establishment and made available to the regulatory authority upon request that include:**
    - a) **A listing of the ready-to-eat food categories that are touched by bare hands;**
    - b) **Handwashing facilities are, equipped, maintained, are easily accessible and in proximity to the work station(s) where the bare hand contact procedure is conducted as specified under §5-208 B, C, D, E;**

- c) **A written employee health policy that details how the food establishment will comply with §2-201, §2-202, §2-203, §2-204, §2-205 and §2-206 including health conditions upon which the food employee will not be allowed to work and acknowledgement of their responsibilities as specified under §2-201 and §2-202;**
- d) **An employee training program that includes:**
  - i. **The risks of contacting the ready-to-eat foods with bare hands;**
  - ii. **Proper handwashing as specified under §2-401;**
  - iii. **When to wash their hands as specified under §2-402;**
  - iv. **Where to wash their hands as specified under §2-404;**
  - v. **Proper fingernail maintenance as specified under §2-405 A;**
  - vi. **Prohibition of jewelry as specified under §2-407 A; and**
  - vii. **Good hygienic practices as related to §2-501 and §2-502.**
- 2. **Hands are washed prior to food preparation and as necessary to prevent cross contamination as specified under §2-401, §2-402, and §2-404 by food employees during all hours of operation when the specific ready-to-eat foods are prepared.**
- 3. **In addition to the requirements specified in §2-402 “When to Wash”, food employees contacting ready-to-eat foods with bare hands utilize two or more of the following control measures to provide additional safeguards to hazards associated with bare hand contact:**
  - a) **Double handwashing;**
  - b) **Nail brushes;**
  - c) **A hand antiseptic after handwashing as specified under §2-403;**
  - d) **Incentive programs that encourage food employees not to work when they are ill with a communicable disease that can be transmitted by foods as specified in §2-201; or**
  - e) **Other control measures approved by the regulatory authority.**
- 4. **Corrective actions are immediately taken when subparagraphs D (1) - (3) of this section are not followed.**
- E. **If a food establishment is found to be in non-compliance with the requirements listed in subparagraphs D (1) - (4) and a civil penalty has been issued in accordance with C.R.S., §25-4-1611 as a result of this non-compliance the regulatory authority may revoke the food establishment’s allowance for food employees to contact ready-to-eat foods with their bare hands.**
- F. **If the allowance for a food establishment to contact ready-to-eat foods with bare hands is voluntarily discontinued by the food establishment or revoked as provided for in subparagraph E, a food establishment may not reinstate bare hand contact**

**with ready-to-eat foods without prior written approval from the regulatory authority.**

**3-302 General**

At all times, including while being stored, prepared, displayed, dispensed, packaged, or transported, food shall be protected from cross-contamination between foods and from potential contamination by insects, insecticides, rodents, rodenticides, other toxins, probe-type price tags or probe-type identification tags, unclean equipment and utensils, unnecessary handling, flooding, draining, overhead leakage or condensation, or other agents of public health significance. Hanging primal cuts and quarters or sides of meat, and uncut raw fruits and vegetables do not need to be over wrapped or covered. Foods in original individual packages must be over wrapped or covered if the package has been torn or broken. During transportation, including transportation to another location for service or catering operations, food shall meet the requirements of these rules and regulations relating to food protection, food storage and temperature maintenance of potentially hazardous foods.

**\*3-303 Cross-Contamination Control**

Each time there is a change in processing between raw beef, raw pork, other raw meats, raw poultry, raw fish and molluscan shellfish or from raw to ready-to-eat foods, food-contact surfaces and utensils shall be cleaned and sanitized in accordance with Chapter 4, part 4-403 of these rules and regulations. Salads and other ready-to-eat foods may also be prepared simultaneously in areas that are separated by a barrier or open space from areas used for processing potentially hazardous raw products.

Slash-resistant gloves used to protect hands during operations requiring cutting shall be handled in a manner which will prevent the cross-contamination between raw and ready-to-eat foods.

**\*3-304 Pasteurized Eggs, Substitute for Shell Eggs for Certain Recipes**

Raw shell eggs shall not be used as an ingredient in the preparation of uncooked, ready-to-eat menu items. Commercially pasteurized egg and egg products may be substituted for raw shell eggs in such items. Pasteurized eggs may also be substituted for raw shell eggs where holding is required for menu items such as scrambled eggs, omelets, French toast, Monte Cristo sandwiches, etc. Pooling of raw shell eggs is allowed only if the eggs are 41°F (5°C) or below when they are cracked and maintained at 41°F (5°C) or below until cooked.

**\*3-305 Washing Fruits and Vegetables/Additives**

- A. All raw fruits and raw vegetables including those that will be cut, combined with other ingredients, or otherwise processed into food products by the retail food establishment shall first be thoroughly cleaned with potable water. Whole, raw fruits and raw vegetables intended for washing by the consumer before consumption need not be washed before sale.
- B. An indirectly drained food preparation sink with an approved eighteen inch (18") 46 cm self-draining drain board or alternate approved methods shall be provided to prevent cross-contamination of clean raw fruits and vegetables. In establishments where vegetable preparation is limited to a few items and in limited quantity, and either single-

service tableware or a mechanical dishwasher is used, the three- compartment sink may be used for food preparation if the sink is indirectly drained and the sink and drain board are cleaned and sanitized between changes in use.

- C. Application of sulfiting agents to fresh fruits (except grapes) and vegetables intended for raw consumption or to a food considered to be a good source of vitamin B<sub>1</sub>; i.e., poultry, crab meat (except canned), mixed nuts, whole grains, whole grain flours, enriched bakery products is prohibited.

### **3-306 In-Use Utensils, Between Use Storage**

To avoid unnecessary manual contact with the food, suitable dispensing utensils and single-service articles shall be used by employees and consumers. Consumer display and self-service of bulk food shall meet the requirements of section 25-4-1301 et seq., C.R.S., (See Appendix I). Dispensing utensils shall be:

- A. Stored in the food with the dispensing utensil handle extended out of the food; or
- B. Stored clean and dry; or
- C. Stored in potable running water as in a running water dipper well; or
- D. Stored at temperatures of 135°F (57°C) and above, or 41°F (5°C) and below.

### **3-307 Wiping Cloths**

- A. Cloths used for wiping food spills on food-contact surfaces shall be cleaned and rinsed frequently in one of the sanitizing solutions permitted in Appendix G of these rules and regulations and used for no other purpose. These cloths shall be saturated with the proper concentration of sanitizing solution.
- B. Cloths used for cleaning nonfood-contact surfaces shall be clean and rinsed as specified in paragraph A of this section and used for no other purpose. These cloths shall be saturated with the proper concentration of sanitizing solution between uses.
- C. Dry or moist cloths that are used with raw foods of animal origin shall be kept separate from cloths used for other purposes. Moist cloths used with raw foods of animal origin shall be kept in a separate sanitizing solution.
- D. Single-use disposable towels are permitted in lieu of wiping cloths or sponges if discarded after each use.
- E. Cloths used for wiping food spills on tableware, such as plates and bowls being served to the consumer, shall be clean, dry, and used for no other purpose.
- F. Sponges shall not be used in contact with cleaned and sanitized or in-use food-contact surfaces.

### **3-308 Re-Use of Tableware**

- A. Re-use of soiled tableware by self-service consumers returning to the service area for additional food is prohibited.

- B. Beverage cups and glasses are exempt from this requirement where filling equipment is designed to prevent cross-contamination.
- C. The dispensing equipment actuating lever or mechanism and filling device of consumer self-service beverage dispensing equipment shall be designed to prevent contact with the lip-contact surface of glasses or cups that are being refilled.

**3-309 Refilling Returnables**

- A. A take-home food container shall not be refilled at a retail food establishment with a potentially hazardous food.
- B. Returnables refilled with food that is not potentially hazardous shall be clean.

**3-310 Food Storage**

- A. Containers of food shall be stored a minimum of six inches (6") [15 centimeters (cm)] above the floor or stored on dollies, skids, racks, or open-ended pallets, provided such equipment is easily movable, either by hand or with the use of pallet-moving equipment that is on the premises and used. Such storage areas shall be kept clean.
- B. Pressurized beverage containers, cased food in waterproof containers such as bottles or cans, milk containers in plastic crates, and waterproof, easily moveable, covered containers may be stored on a floor that is clean and not exposed to floor moisture.
- C. Packaged food, once the container is opened in the retail food establishment prior to use or retail sale, shall be kept covered. Food, whether raw or prepared, if removed from the container in which it was originally packaged, shall be stored in a clean, covered container, except during necessary periods of preparation.

Primal cuts, quarters or sides of meat, or processed meats, such as country hams, slab bacon, and smoked or cured sausages, may be hung uncovered or placed on clean, sanitized metal racks in such a manner as to preclude contamination of any food products in storage.

**3-311 Food Storage, Prohibited Areas**

Food may not be stored:

- A. In locker areas unless the food is completely packaged;
- B. In toilet rooms and their vestibules;
- C. In dressing rooms;
- D. In garbage rooms;
- E. In mechanical rooms;
- F. Under sewer lines that are not shielded to intercept potential drips;
- G. Under leaking water lines, including leaking automatic fire sprinkler heads, or under lines on which water has condensed;
- H. Under other sources of contamination; or

I. In recycling rooms.

**3-312 Food Display**

- A. Except for nuts in the shell and whole, raw fruits and vegetables that are intended for hulling, peeling, or washing by the consumer before consumption, food on display shall be protected from contamination by the use of packaging; food shields at counters, service lines, or salad bars; display cases; or other effective means of protection.
- B. French style, hearth baked or hard-cruste d loaves and rolls may be considered properly wrapped if contained in an open-end bag of sufficient size to enclose the loaves or rolls.
- C. Bulk food that is available for consumer self-dispensing shall meet the requirements of section 25-4-1301 et seq., C.R.S., (See Appendix I).

**3-313 Condiments, Protection**

Condiments shall be protected from contamination by being kept in protective dispensers, in food displays provided with the proper utensils, in original containers that are designed for dispensing, or in individual packages or portions.

**\*3-314 Consumer Self-Service Operations**

Unpackaged or unwrapped raw animal food, such as beef, lamb, pork, poultry and fish shall not be offered for consumer self-service. This does not apply to consumer self-service of ready-to-eat foods at buffets or salad bars that serve foods such as sushi or raw shellfish, or to ready-to-cook individual portions for immediate cooking and consumption on the premises such as consumer-cooked meats or consumer-selected ingredients for Mongolian barbecue.

**\*3-315 Reservice**

Once served to a consumer, portions of leftover food shall not be served again except that packaged food, other than potentially hazardous food, that is still in an unopened package and is still in sound condition, may be re-served.

**3-4 DESTRUCTION OF ORGANISMS OF PUBLIC HEALTH CONCERN**

**\*3-401 Temperature**

- A. The temperature of potentially hazardous foods shall be 41°F (5°C) or below or 135°F (57°C) or above, at all times, except during necessary periods of preparation or as otherwise provided in this code.
- B. Equipment for cooling, heating and holding food, cold and hot, shall be sufficient in number and capacity to provide required food temperatures.
- C. Fluid milk and milk products, molluscan shellstock, and shell eggs may be received at their respective temperatures according to laws governing their distribution.

**\*3-402 Cooking Potentially Hazardous Foods**

Unless otherwise ordered by the immediate consumer, potentially hazardous foods processed within the retail food establishment shall be cooked to a uniform internal temperature of 140°F (60°C), except that:

- A. Poultry, stuffed fish, stuffed meat, stuffed pasta, stuffed poultry, or stuffing containing fish, meat or poultry shall be cooked to a uniform internal temperature of at least 165°F (74°C) for 15 seconds.
- B. Rare roast beef and rare beef steak shall be cooked to a uniform internal temperature of at least 130°F (55°C).
- C. Eggs, pork, lamb, fish and other meats as defined in section 1-202 (35) shall be cooked to a uniform internal temperature of 145°F (63°C) for 15 seconds.
- E. Ground beef shall be cooked to a uniform internal temperature of 155°F (68°C) for 15 seconds, or to 145°F (63°C) for 3 minutes, or 150°F (66°C) for 1 minute, or 158°F (70°C) for less than one second.
- F. Game animals shall be cooked to a uniform internal temperature of 155°F (68°C) for 15 seconds.
- G. Comminuted fish, meat and game animals shall be cooked to a uniform internal temperature of 155°F (68°C) for 15 seconds.
- H. Raw animal foods cooked in a microwave oven shall be:
  - 1. Rotated or stirred throughout or midway during cooking to compensate for uneven distribution of heat;
  - 2. Covered to retain surface moisture;
  - 3. Heated to a temperature of at least 165°F (74°C) in all parts of the food; and
  - 4. Allowed to stand covered for 2 minutes after cooking to obtain temperature equilibrium.
- I. Fruits and vegetables that are cooked for hot holding shall be cooked to a temperature of 135°F (60°C).

**\*3-403 Reheating**

- A. Except as specified under paragraphs (B) and (C) of this section, potentially hazardous foods that have been cooked and then refrigerated shall be rapidly reheated within two hours to a uniform internal temperature of 165°F (74°C) or higher before being placed in hot food storage holding units which shall maintain product temperature at 135°F (57°C) or above at all times. Food warmers and other hot food holding units shall not be used to reheat potentially hazardous foods unless the equipment is specifically designed for that purpose. If a retail food establishment proposes to use equipment for reheating that is not designed for reheating, written procedures documenting use must be approved by the Department.

- B. Except as specified in paragraph (C) of this section, food reheated in a microwave oven shall be heated to a uniform internal temperature of at least 165°F (74°C) and the food is rotated or stirred, covered, and allowed to stand covered for 2 minutes after reheating.
- C. Ready-to-eat food taken from a commercially processed, hermetically sealed container, or from an intact package from a food processing plant that is inspected by the food regulatory authority that has jurisdiction over the plant, shall be heated to a uniform internal temperature of at least 135°F (60°C) for hot holding.
- D. Cooked and refrigerated food that is prepared for immediate service in response to an individual consumer order, such as a roast beef sandwich au jus, may be served at any temperature.

### **3-5 LIMITATION OF GROWTH OF ORGANISMS OF PUBLIC HEALTH CONCERN**

#### **3-501 Thawing**

Potentially hazardous foods shall be thawed:

- A. Under refrigeration or conditions that maintain the food temperature at 41°F (5°C) or below;
- B. Completely submerged under running water:
  - 1. At a water temperature of 70°F (21°C) or below, and
  - 2. With sufficient water velocity to agitate and float off loose particles in an overflow, and
  - \*3. For a period of time that does not allow thawed portions of food to rise above 41°F (5°C) for more than four hours.
- C. In a microwave oven only when the food will be immediately transferred to a conventional cooking process as part of a continuous operation, or when the entire, uninterrupted cooking process takes place in the microwave oven, or returned immediately to cold storage.
- \*D. Under conditions that do not allow any portions of the food to be above 41°F (5°C).
- E. As part of the conventional cooking process.

#### **\*3-502 Cooling**

- A. Cooked potentially hazardous food shall be cooled from 135°F (57°C) to 41°F (5°C), or below, in 6 hours, provided that the food is cooled from 135°F (57°C) to 70°F (21°C) within the first 2 hours.
- B. Potentially hazardous food that has been prepared from ingredients at ambient temperature, such as reconstituted milk and canned products, shall be cooled to 41°F (5°C), or below, within 4 hours.

- C. Fluid milk and milk products, shell eggs, and molluscan shellstock received in compliance with laws regulating the respective food during shipment from the supplier shall be cooled to 41°F (5°C) or below within 4 hours.

**3-503 Cooling Methods**

- A. Cooling shall be accomplished as required in section 3-502, by using one or more of the following methods based on the type of food being cooled:
  - 1. Placing the food in shallow pans;
  - 2. Separating the food into smaller or thinner portions;
  - 3. Using rapid cooling equipment;
  - 4. Stirring the food in a container placed in an ice water bath;
  - 5. Using containers that facilitate heat transfer;
  - 6. Adding ice as an ingredient; or
  - 7. Other effective methods that meet the requirements of section 3-502 of these rules and regulations.
- B. When using food containers to cool food, food shall be:
  - 1. Arranged in the container to provide maximum heat transfer through the container walls; and
  - 2. Loosely covered, or uncovered if protected from overhead contamination during the cooling period to facilitate heat transfer from the surface of the food.

**\*3-504 Time as a Public Health Control**

Time only, rather than time in conjunction with temperature, may be used as the public health control for a working supply of potentially hazardous food before cooking, or for ready-to-eat potentially hazardous food that is displayed or held for service for immediate consumption, if:

- A. The food is marked or, otherwise identified, with the time within which it shall be cooked, served, or discarded;
- B. The food is served or discarded within 4 hours from the point in time at which the food was removed from temperature control;
- C. Food in unmarked containers or packages, or for which the time expires, is discarded; and
- D. Written procedures approved by the Department that ensure compliance with paragraphs A-C of this section are maintained in the establishment and made available to the regulatory authority upon request.
- E. In a retail food establishment that serves a highly susceptible population, time and temperature shall be used as a public health control for raw eggs.

**\*3-505 Modified Atmosphere Packaging, Criteria**

- A. A retail food establishment that packages food using a modified atmosphere packaging method shall have a HACCP plan that contains the information specified under Appendix H and that:
1. Identifies the food to be packaged;
  2. Limits the food packaged to a food that does not support the growth of *Clostridium botulinum* because it:
    - a) Has an  $a_w$  of 0.91 or less,
    - b) Has a pH of 4.6 or less,
    - c) Is a meat product cured at a processing plant regulated by the U.S. Department of Agriculture using a combination of nitrites, nitrates, and salt that at the time of processing consists of 120 mg/L or higher concentration of sodium nitrite and a brine concentration of at least 3.50% and is received in an intact package, or
    - d) Is a food with a high level of competing organisms such as raw meat or raw poultry.
  3. Specifies methods for maintaining food at 41°F (5°C) or below;
  4. Describes how the packages shall be prominently and conspicuously labeled on the principal display panel in bold type on a contrasting background, with instructions to:
    - a) Maintain the food at 41°F (5°C) or below, and
    - b) Discard the food if not consumed within 14 calendar days of its packaging.
  5. Limits the refrigerated shelf life to no more than 14 calendar days from packaging to consumption, or the original manufacturer's "sell by" or "use by" date, whichever occurs first;
  6. Includes operational procedures that:
    - a) Minimize handling of food with bare hands,
    - b) Identify a designated area and the method by which:
      - i) Physical barriers or methods of separation of raw foods of animal origin and ready-to-eat foods minimize cross-contamination, and
      - ii) Access to the processing equipment is restricted to responsible trained personnel familiar with the potential hazards of the operation, and
      - iii) Delineate cleaning and sanitization procedures for food-contact surfaces;

7. Describes the training program that assures the individual responsible for the modified atmosphere packaging operation understands the:
  - a) Concepts required for a safe operation,
  - b) Equipment and facilities, and
  - c) Procedures specified in subparagraph (A)(6) of this section and Appendix H.
- B. Except for fish that is frozen before, during and after packaging, a food establishment may not package fish using a modified atmosphere packaging method.

### **3-6 ON-PREMISES LABELING**

#### **3-601 Labeling**

- A. When voluntary code date information appears on a retail food establishment or manufacturers' label, it shall not be concealed or altered.
- B. Bulk food available for consumer self-dispensing shall be prominently labeled according to section 25-4-1301 et seq., C.R.S., (See Appendix I).
- C. If an unpackaged non-bulk food product is manufactured on site and sold at the site where it was manufactured or sold over the counter at a different site, no labeling is required. However, an ingredient label shall be made available upon request.

If the product is distributed at a location different from the manufacturing site, as a prepackaged item, it must be labeled in accordance with section 25-5-401 et seq., C.R.S. and all labeling regulations authorized therein.
- D. A food ingredient, such as flour, sugar, salt, spices, baking powder, cooking oil or vinegar, that is not stored in the original package and is not readily identifiable on sight, shall be stored in a container identifying it by a common name.

#### **\*3-602 Special Requirements for Highly Susceptible Populations**

The following foods may not be served or offered for sale in a ready-to-eat form to persons in a highly susceptible population:

- A. Raw animal foods such as raw fish, raw-marinated fish, raw molluscan shellfish, and steak tartare;
- B. A partially cooked animal food such as lightly cooked fish, rare meat, soft cooked eggs that are made from raw shell eggs and meringue;
- C. Raw seed sprouts; and
- D. Juice that is not pasteurized or treated under an HACCP plan as specified in Appendix I of these rules and regulations, or contains a warning label as specified in Section 3-211(B) of these rules and regulations.

## CHAPTER 4

### WAREWASHING, EQUIPMENT, UTENSILS, AND LINENS

#### 4-1 MATERIALS FOR CONSTRUCTION AND REPAIR

##### 4-101 General

All equipment, utensils and single-service articles shall be fabricated with safe materials; be of commercial design, that is certified or classified for sanitation by an American National Standards Institute (ANSI) accredited certification program or a design approved by the Department (see Appendix J); fabricated for durability under conditions of normal use; and resistant to denting, buckling, pitting, chipping, and crazing. Equipment, utensils, and single-service articles shall not impart odor, color, or taste, nor in any manner contribute to the contamination of food. Equipment and utensils shall be repaired with safe materials and maintained in good repair to comply with the requirements of this code.

##### 4-102 Equipment Requirements

All retail food establishments shall have at a minimum:

- A. Equipment and utensil washing facilities installed and operated in accordance with section 4-403 of these rules and regulations;
- B. Handsinks accessible to employees involved in food preparation and equipment and utensil washing in accordance with section 5-207 of these rules and regulations; and
- C. A utility facility in accordance with section 5-210 of these rules and regulations.

#### 4-2 DESIGN AND CONSTRUCTION

##### 4-201 Food Contact Surfaces

Multi-use food-contact surfaces shall be:

- A. Smooth;
- B. Free of breaks, open seams, cracks, chips, pits, and similar imperfections;
- C. Free of sharp internal angles, corners, and crevices;
- D. Finished to have smooth welds and joints; and
- E. Accessible for cleaning and inspection by one of the following methods:
  1. Without being disassembled,
  2. By disassembly without the use of tools, or
  3. By easy disassembly with the use of only simple tools, such as mallets, screw drivers, or wrenches, that are kept in a readily accessible location near the equipment.

**4-202 Use Limitations**

- A. Cast iron may only be used as a cooking surface which can include use in the service of food when used in an uninterrupted process from cooking through service.
- B. Ceramic, china, crystal utensils, and decorative utensils, such as hand-painted ceramic or china, that are used in contact with food shall be lead-free or contain levels of lead not exceeding the limits of the following utensil categories:

<b>UTENSIL CATEGORY</b>	<b>DESCRIPTION</b>	<b>MAXIMUM LEAD mg/L</b>
Hot Beverage Mugs	Coffee Mugs	0.5
Large Hollowware	Bowls $\geq$ 1.1 L (1.16 QT)	1
Small Hollowware	Bowls $<$ 1.1 L (1.16 QT)	2.0
Flat Utensils	Plates, Saucers	3.0

- C. Copper and copper alloys, such as brass, may not be used in contact with food that has a pH below 6 (e.g. vinegar, fruit juice, wine, etc.) or used for a fitting or tubing installed between a backflow prevention device and a carbonator.  
  
Copper and copper alloys may be used in contact with beer brewing ingredients that have a pH below 6 in the prefermentation and fermentation steps of a beer brewing operation such as a brewpub or microbrewery.
- D. Enamelware is prohibited for any food-contact surface.
- E. Galvanized metal may not be used to fabricate food-contact surfaces of equipment that is used for beverages, moist food, or hygroscopic food.
- F. Clean linens and napkins may be used to line containers used for the service of foods, if the linens and napkins are replaced each time the container is refilled for a new consumer.
- G. Clean cloth gloves may be used in direct contact with food that will be subsequently cooked as required under part 3-4, such as frozen food or a primal cut of meat.
- H. Pewter may not be used as a food-contact surface.
- I. Solder and flux containing lead in excess of 0.2%, and cadmium, antimony, bismuth, or other toxic chemicals may not be used on surfaces that contact food.
- J. Except as specified in paragraphs 1, 2, and 3 of this section, wood and wicker may not be used as a food-contact surface.
  - 1. Hard maple or an equivalently hard, close-grained, nonabsorbent wood, provided it is not cracked, pitted or uncleanable, may be used for:

- a) Cutting boards, cutting blocks, bakers' tables, bagel boards, and utensils such as rolling pins, doughnut dowels, salad bowls, pizza paddles, and chopsticks; and
  - b) Wooden paddles used in confectionery operations for pressure scraping kettles when manually preparing confections at a temperature of 230°F (110°C) or above.
- 2. Whole, uncut, raw fruits and vegetables, and nuts in the shell may be kept in the original wood or wicker containers until the fruits, vegetables, or nuts are used.
- 3. If the nature of the food requires removal of rinds, peels, husks, or shells before consumption, the whole, uncut, raw food may be kept in:
  - a) Untreated wood or wicker containers; or
  - b) Treated wood containers if the containers are treated with a preservative that meets the requirements specified by the Department in Preservatives for Wood, 21 CFR §178.3800, (2003).
- K. Cutting surfaces that are scratched and scored must be resurfaced so as to be easily cleaned, or be discarded when these surfaces can no longer be effectively cleaned and sanitized.
- L. Newspapers, cloth, paper, cardboard, towels, contact paper, foil, oil cloth, or similar materials shall not be used as liners for shelves, drawers, or drain boards.
- M. Wrapping of utensils or equipment handles with absorbent or difficult-to-clean material, such as string, wire or tape shall not be allowed.

#### **4-203 Nonfood-Contact Surfaces**

Nonfood-contact surfaces shall be constructed of approved materials, in good repair, and be easily maintained in a clean and sanitary condition.

- A. In new or extensively remodeled retail food establishments, wood interior construction in walk-in cooler and freezer units shall be prohibited.
- B. Unfinished wood is not acceptable in food preparation, equipment or warewashing, or food storage areas other than those areas used solely as dry food storage areas.
- C. Surfaces of equipment or other areas, which are exposed to splash, food debris or which otherwise require frequent cleaning, shall be designed and fabricated to be smooth, durable, washable, free of unnecessary ledges, projections, or crevices, and readily accessible for cleaning.
- D. Wicker and wicker-like materials, in good repair can be used for service and display of prepackaged food. Service of bread or rolls in wicker or wicker-like materials is permissible if lined with dry linens or napkins, which are replaced each time the container is refilled for a new customer.

#### **4-204 Clean In Place (CIP) Equipment**

- A. CIP equipment shall meet the characteristics of food-contact surfaces and shall be designed and constructed so that:
  - \*1. Cleaning and sanitizing solutions circulate throughout a fixed system and contact all interior food-contact surfaces; and
  - 2. The system is self-draining or capable of being completely drained of cleaning and sanitizing solutions.
- B. CIP equipment that is not designed to be disassembled for cleaning shall be designed with inspection access points to ensure that all interior food-contact surfaces throughout the fixed system are being effectively cleaned.

#### **4-205 “V” Threads, Use Limitation**

“V” type threads may not be used on food-contact surfaces, except for hot-oil cooking or filtering equipment.

#### **4-206 Hot-Oil Filtering Equipment**

Hot-oil filtering equipment shall meet the characteristics specified under food-contact surfaces (section 4-201) or CIP equipment (section 4-204) and shall be readily accessible for filter replacement and cleaning of the filter.

#### **4-207 Bearings and Gear Boxes, Leakproof**

Equipment containing bearings and gears requiring lubricants not made of safe materials shall be designed, constructed and maintained to ensure that the lubricant cannot leak, drip, or be forced into food or onto food-contact surfaces. Equipment designed to receive lubrication of bearings and gears on or within food-contact surfaces shall be lubricated with materials meeting the requirements of Lubricants, 21 CFR §178.3570, (2003) (see Appendix F).

#### **4-208 Beverage Tubing, Separation**

Beverage tubing and cold-plate beverage cooling devices shall not be installed in contact with stored ice. This section does not apply to cold plates that are constructed integrally with an ice storage bin.

#### **4-209 Ice Units, Separation of Drains**

Liquid waste drain lines may not pass through an ice machine or ice storage bin.

#### **4-210 Condenser Unit, Separation**

If a condenser unit is an integral component of equipment, the condenser unit shall be separated from the food and food storage space by a dustproof barrier.

**\*4-211 Molluscan Shellfish Tanks**

Molluscan shellfish life-support system display tanks may only be used to display shellfish not offered for human consumption.

**4-212 Ventilation and Ventilation Hood Systems**

All rooms shall have sufficient ventilation to keep them free of excessive heat, steam, condensation, vapors, obnoxious odors, smoke, and fumes. Ventilation systems shall comply with applicable building department and fire prevention bureau requirements, and when vented to the outside shall not create an unsightly, harmful, or unlawful discharge. All ventilation systems shall comply with the 2000 Uniform Mechanical Code. When local building and/or fire departments have adopted codes equivalent or more stringent than the above, those codes shall apply.

- A. Ventilation Hood Systems. Ventilation hood systems shall be sufficient in number, capacity, and designed and constructed according to the 2000 Uniform Mechanical Code, section 402.4, chapter 4, and sections 507 and 508, chapter 5. Ventilation hood systems and devices shall be designed to prevent grease or condensation from collecting on walls and ceilings, and from dripping into food or onto food-contact surfaces. Filters or other grease extracting equipment shall be easily removable for cleaning and replacement when not designed for in place cleaning.
- B. Special Ventilation. Equipment from which aerosols, obnoxious odors, noxious fumes, or vapors may originate shall be effectively vented to the outside air or vented through an approved ventilation system. All grease-producing equipment shall be vented through a properly designed ventilation hood and grease collection system. Condensate-producing equipment may be vented to the outside in mobile units and food establishments through exhaust air ducts or by flow-through ventilation provided no nuisance is created.
  - 1. Intake and exhaust ducts shall be maintained to prevent the entrance of dust, dirt, and other contaminating materials.
  - 2. In new or extensively remodeled retail food establishments, all rooms, including restrooms, from which obnoxious odors, vapors, or fumes originate shall be mechanically vented to the outside unless exempted under paragraph B of this section.
- C. Fire Prevention Equipment and Lighting Systems. Fire prevention, extinguishing equipment and lighting systems shall be installed in a ventilation system or hood so as to not create a cleaning problem.

**4-3 LOCATION AND INSTALLATION**

**4-301 Equipment, and Storage Cabinets, Contamination Prevention.**

- A. The storage of cleaned and sanitized equipment, utensils, laundered linens, laundered clothing and single-service and single-use articles may not be located:
  - 1. In locker areas;

2. In toilet rooms and their vestibules;
  3. In dressing rooms;
  4. In garbage rooms;
  5. In mechanical rooms;
  6. Under water and sewer lines that are not shielded to intercept potential drips;
  7. Under leaking automatic fire sprinkler heads, or under lines on which water has condensed;
  8. Under other sources of contamination; or
  9. In recycling rooms.
- B. A storage cabinet used for linens or completely packaged single-service or single-use articles may be stored in a locker area.

**4-302 Fixed Equipment, Spacing or Sealing**

Equipment, including ice makers and ice storage equipment, shall not be located under sewer lines that are not shielded to intercept potential drips or under leaking water lines, including leaking automatic fire sprinkler heads, or under lines on which water has condensed.

A. Table-Mounted Equipment

1. Table-mounted equipment shall be installed to facilitate the cleaning of the equipment and the adjacent areas.
2. Equipment that is mounted on tables or counters, unless portable, shall be sealed to the table or counter, or elevated on legs to provide at least a 4-inch (10 cm) clearance between the table or counter, except that if no part of the table under the equipment is more than 18 inches (46 cm) from cleaning access, the clearance space shall be three (3) inches (8 cm) or more; or if no part of the table under the equipment is more than three (3) inches (8 cm) from cleaning access, the clearance space shall be two (2) inches (5 cm) or more.
3. Equipment is portable within the meaning of section 4-302(A)(2) of this code if:
  - a) It is small and light enough to be moved easily by one person; or
  - b) Is equipped with a mechanical means of safely tilting the unit for cleaning; and
  - c) It is table-mounted, such as powered mixers, grinders, slicers, tenderizers, and similar equipment; and
  - d) It has no utility connection, has a utility connection that disconnects quickly, or has a flexible utility connection line of sufficient length to permit the equipment to be moved for easy cleaning.

B. Floor-Mounted Equipment

1. Floor-mounted equipment, unless easily moveable, shall be:
  - a) Sealed to the floor; or
  - b) Elevated on sanitary legs to provide at least a 6-inch (15 cm) clearance between the floor and equipment, except that equipment may be elevated to provide at least a 4-inch (10 cm) clearance between the floor and equipment if the floor under the equipment is no more than six (6) inches (15 cm) from cleaning access;
  - c) Display shelving units, display refrigeration units, and display freezer units are exempt from the provisions of Paragraph 1, a and b of this section if they are installed so that the floor beneath the units can be cleaned.
2. Equipment is easily moveable if:
  - a) It is mounted on commercially designed wheels or casters; and
  - b) It has no utility connection, or has a utility connection that disconnects quickly, or has a flexible utility line of sufficient length to permit the equipment to be moved for easy cleaning.
3. Grease-Use Equipment. Grease-use equipment, in which fats and oils are utilized as the heat transfer agent or which is used in preparation of foods that produce grease, shall be installed to facilitate cleaning around and beneath the equipment by means of:
  - a) Rollers or casters with a utility connection that disconnects quickly, or has a flexible utility line of sufficient design and length to permit the equipment to be moved for easy cleaning; or
  - b) Mounted on 6 inch (15.24 cm) sanitary legs; or
  - c) Cantilever mounted to the wall at least 6 inches (15.24 cm) above the floor.

C. Space Between Adjoining Units

1. The space between adjoining units, and between or above a unit and the adjacent wall or ceiling, shall be closed unless exposed to seepage, in which event it shall be sealed; or sufficient space shall be provided to facilitate easy cleaning between, behind, and beside or above all such equipment. (See Figure. 1 and Figure 2.)
2. Space required between or behind walls or equipment shall be based on the following distances: (See Figure. 1 and Figure. 2)
  - a) When distance "A" is 2 feet (0.61 M) or less, distance "B" must be at least 6 inches (15 cm).
  - b) When distance "A" is over 2 feet (0.61 M) but less than 6 feet (1.8 M), distance "B" must be at least 12 inches (30 cm).

- c) When distance “A” is 6 feet (1.8 M) or more, then distance “B” must be at least 18 inches (46 cm).
3. When rollers or casters are installed on equipment, the space requirements between adjoining units may not apply.

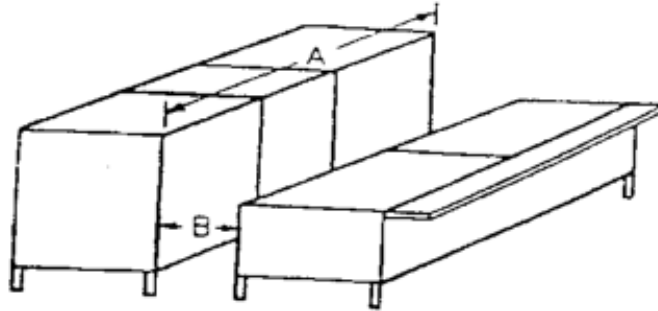

FIGURE 1

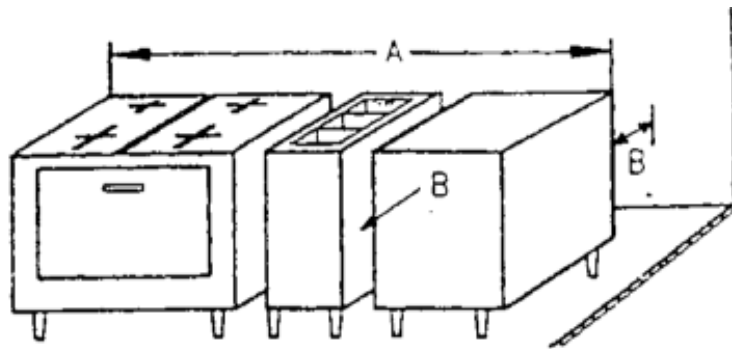

FIGURE 2

- D. Aisles and Working Spaces. Aisles and working spaces between units of equipment and between equipment and walls shall be unobstructed and of sufficient width to permit employees to perform their duties readily without contamination of food or food-contact surfaces by clothing or personal contact. All easily moveable storage equipment such as dollies, skids, racks, and open-ended pallets shall be positioned to provide accessibility to working areas.
- E. Kick Plates, Removable. Kick plates shall be designed so that the areas behind them are accessible for inspection and cleaning by being:
1. Removable by one of the methods specified in section 4-201(E)(1-3) of these rules and regulations or capable of being rotated open; and
  2. Removable or capable of being rotated open without unlocking equipment doors.

#### **4-4 TESTING DEVICES - CLEANING FACILITIES**

##### **4-401 Thermometers**

Indicating thermometers shall be provided and used. Thermometers with glass sensors and stems encased in a shatterproof coating may be used. A food product thermometer shall be cleaned and sanitized before use or storage.

- A. \*Food product thermometers shall be capable of reading both hot and cold temperatures, and shall have a numerical scale (0°-220°F), printed record, or digital readout in increments no greater than 2°F (1°C). Food product thermometers shall be used to determine required food temperature(s) and shall be accurate to ±2°F (1°C).
- B. A temperature measuring device that is capable of measuring the temperature of thin masses shall be provided and readily accessible to accurately measure the temperature in thin foods such as meat patties and fish fillets, if this type of food is prepared.
- C. Ambient air and warewashing thermometers shall have a numerical scale, printed record, or digital readout in increments no greater than 2°F or 1°C and shall be accurate to ±3°F (2°C).
- D. Each mechanically refrigerated and each hot food storage unit storing potentially hazardous food shall be provided with a numerically scaled indicating thermometer. Thermometers used to measure the air temperature of cold holding units shall be conspicuously located in the upper one-third of the unit. Thermometers used to measure the air temperature of hot food storage units shall be conspicuously located in the lower one-third of the unit.
- E. Thermometers shall be calibrated as necessary to ensure their accuracy.
- F. Where it is impractical to install thermometers on equipment, such as heat lamps, calorod units, or insulated food transport carriers, a food product thermometer, as required in part A of this section, shall be available and used to check internal food temperature.

##### **4-402 Sanitizing Solutions, Testing Devices**

A test kit or other device that accurately measures the concentration in parts per million (mg/L) of the sanitizing solution shall be available and used.

##### **4-403 Equipment and Utensil Cleaning and Sanitization**

- A. Manual Cleaning and Sanitization
  - 1. Except as specified in paragraph 3 of this section, a sink with at least three compartments shall be provided for manually washing, rinsing, and sanitizing equipment and utensils. Each compartment of the sink shall be supplied with hot and cold potable running water.
  - 2. Sink compartments shall be self-draining and large enough to accommodate immersion of the largest equipment and utensils. If equipment or utensils are too large for the sink compartments, a warewashing machine or alternative equipment as specified in paragraph 3 of this section shall be used.

3. Alternative manual warewashing equipment may be used when there are special cleaning needs or constraints and the regulatory authority has approved the use of the alternative equipment. Alternative manual warewashing equipment may include:
  - a) High-pressure detergent sprayers;
  - b) Low- or line-pressure spray detergent foamers;
  - c) Other task-specific cleaning equipment;
  - d) Brushes or other implements;
  - e) Two-compartment sinks as specified under paragraph 4 of this section.
  
4. A two-compartment sink may be used in an existing retail food establishment only if:
  - a) The Department has approved its use; and
  - b) The nature of warewashing is limited to batch operations such as between cutting one type of raw meat and another or cleanup at the end of a shift, where the number of items cleaned is limited, and where the cleaning and sanitizing solutions are made up immediately before use and drained immediately after use. \*If a detergent-sanitizer is used to sanitize in a cleaning and sanitizing procedure where there is not a distinct water rinse between the washing and sanitizing steps, then the detergent-sanitizer shall be approved and used according to the manufacturer's specifications.
  - c) A two-compartment sink may not be used for warewashing operations such as where cleaning and sanitizing solutions are used for a continuous or intermittent flow of kitchenware or tableware in an ongoing warewashing process.
  
5. In manual warewashing operations, a thermometer shall be provided and readily accessible for frequently measuring the washing and sanitizing temperatures. The temperature of the wash solution shall be maintained at not less than 110°F (43°C) unless a different temperature is specified on the cleaning agent manufacturer's label instructions.
  
6. Approved self-draining drainboards, or utensil racks large enough to accommodate all soiled and cleaned items that may accumulate during hours of operation shall be provided for necessary utensil holding before cleaning and after sanitizing. Alternate approved methods may be used in lieu of the drainboard sizing specified according to the following:

<u>Facility</u>	<u>Clean Drainboards</u>	<u>Soiled Drainboards</u>
Bar Sink	Eighteen Inches (18") (46 cm)	Eighteen Inches (18") (46 cm)
Single Service	Twenty-four Inches (24")	Twenty-four Inches (24")

	( 61 cm)	( 61 cm)
Multi-use Service	Thirty-six Inches (36") (91 cm)	Thirty-six Inches (36") (91 cm)

7. Equipment and utensils shall be pre-flushed or pre-scraped, and when necessary, pre-soaked to remove gross food particles and soil.
8. When a three-compartment sink is utilized for warewashing, the operation shall be conducted in the following sequence:
  - a) The sinks shall be cleaned and sanitized before use; and
  - b) Equipment and utensils shall be thoroughly cleaned in the first compartment with a hot (not less than 110°F [43°C]) detergent solution that is kept clean and at a concentration indicated on the manufacturer's label; and
  - c) Equipment and utensils shall be rinsed free of detergent and abrasive with clean water in the second compartment; and
  - \*d) Equipment and utensils shall be sanitized in the third compartment according to one of the methods included in section 4-403 (A)(10)(b-d) of these rules and regulations.
- \*9. When pressure spray methods are utilized for cleaning and sanitizing, the equipment and utensils shall be thoroughly flushed with a detergent-sanitizer solution until the article is free of food particles and soil. The detergent-sanitizer shall be used in accordance with the manufacturer's instructions and shall be of the type that does not require a potable water rinse when used according to those instructions.
- \*10. The food-contact surfaces of all equipment and utensils shall be sanitized by:
  - a) Immersion for at least ½ minute in clean, hot water of a temperature of at least 170°F (77°C); or
  - b) Immersion for at least 1 minute in a clean solution containing a minimum of 50 parts per million (mg/L) and no more than 200 parts per million (mg/L) of available chlorine as a hypochlorite and having a temperature of at least 75°F (24°C); or
  - c) Immersion for at least 1 minute in a clean solution containing at least 12.5 parts per million (mg/L) of available iodine, having a pH range not higher than 5.0, unless otherwise certified to be effective by the manufacturer, and at a temperature of at least 75°F (24°C); or
  - d) Immersion in a clean solution containing a quaternary ammonia product or any other chemical sanitizing agent allowed under Sanitizers, 21 CFR §178.1010, (2003).
  - e) Treatment with steam that is free from materials or additives other than those specified in 21 CFR §173.310, (2003) in the case of equipment too large to sanitize by immersion, but in which steam can be confined; or

- f) Rinsing, spraying, or swabbing with a chemical sanitizing solution containing at least the strength required for that particular sanitizing solution under section 4-403(A)(10)(b through d) of these rules and regulations for equipment too large to sanitize by immersion.
- \*11. When hot water is used for sanitizing, the following equipment shall be provided and used:
- a) An integral heating device or fixture installed in, on, or under the sanitizing compartment of the sink which is capable of maintaining the water at a temperature of at least 170°F (77°C); and
  - b) A numerically-scaled indicating thermometer, accurate to  $\pm 3^{\circ}\text{F}$  ( $\pm 2^{\circ}\text{C}$ ), located convenient to the sink for frequent checks of water temperature; and
  - c) Utensil racks, baskets, or other appropriate means to permit complete immersion of utensils and equipment in the hot water.
- \*12. Chemicals used for sanitization, shall not have concentrations higher than the maximum permitted under Sanitizers, 21 CFR §178.1010, (2003).

B. Mechanical Cleaning and Sanitization

- \*1. Cleaning and sanitizing may be done by spray-type, immersion warewashing, or by any other type of machine or device if it is demonstrated that it thoroughly cleans and sanitizes equipment and utensils. These machines and devices shall be properly installed and maintained in good repair. Machines and devices shall be operated in accordance with manufacturer's instructions. Utensils and equipment placed in the machine shall be exposed to all warewashing cycles. Automatic detergent dispensers, wetting agent dispensers, and liquid sanitizer injectors shall be properly installed and maintained.
2. The pressure of final rinse water supplied to spray-type warewashing machines shall not be less than 15 pounds per square inch (1.05 kg per sq cm) nor more than 25 pounds per square inch (1.76 kg per sq cm) measured in the water line immediately upstream from the final rinse control valve. A 1/4 inch (6.4 millimeters) Iron Pipe Size (IPS) valve shall be provided immediately upstream from the final control valve to permit checking the flow pressure of the final rinse water. In all new installations, a pressure gauge shall be provided for use with the IPS valve. This section does not apply to a machine that uses only a pumped sanitizing rinse.
3. Machine or water-line mounted numerically-scaled indicating thermometers, accurate to  $\pm 3^{\circ}\text{F}$  ( $\pm 2^{\circ}\text{C}$ ), shall be provided to indicate the temperature of the water in each tank of the machine and the temperature of the final rinse water as it enters the manifold.
4. Rinse water tanks shall be protected by baffles, curtains, or other effective means to minimize the entry of wash water into the rinse water. Conveyors in warewashing machines shall be accurately timed to ensure proper exposure times in wash and rinse cycles in accordance with manufacturer's specifications attached to the machines.
5. Self-draining drainboards shall be provided and be large enough to accommodate all soiled and cleaned items. Drainboards or alternate approved equipment shall not be located and constructed in a manner that interferes with the proper use of the warewashing facilities.
6. Equipment and utensils shall be flushed or scraped and, when necessary, soaked to remove gross food particles and soil prior to being washed in a warewashing machine unless a pre-wash cycle is a part of the warewashing machine operation. Equipment and utensils shall be placed in racks, trays, or baskets, or on conveyors, in a way that exposes food-contact surfaces to the unobstructed application of detergent wash and clean rinse waters, and that permits free draining.
7. Chemical sanitizing warewashing machines (single-tank, stationary-tank, door-type machines, and spray-type glass washers) may be used provided that:
  - a) The temperature of the wash water shall not be less than 120°F (49°C);
  - b) The wash water shall be kept clean; and

- c) Chemicals added for sanitization purposes shall be automatically dispensed; and
- \*d) Utensils and equipment shall be exposed to the final chemical sanitizing rinse in accordance with the manufacturer's specifications for time and concentration; and
- \*e) The chemical sanitizing rinse water temperature shall not be less than 75°F (24°C) nor less than the temperature specified by the machine's manufacturer; and
- \*f) Chemical sanitizers shall meet the requirements specified in 21 CFR §178.1010, (2003) Sanitizing solutions.

\*8. Hot water sanitizing warewashing machines may be used, provided that wash water and pumped rinse water is kept clean and the wash solution temperature is maintained at not less than the temperatures stated in this section, 4-403(B)(8)(a-e) of these rules and regulations.

Achieving a utensil and/or equipment surface temperature of 160°F (71°C) is an acceptable means of testing the sanitization process of a hot water sanitizing warewashing machine.

- a) Single-tank, stationary-rack, dual-temperature machines:
 

Wash temperature	150°F (66°C)
------------------	--------------
- b) Single-tank, stationary-rack, single-temperature machine:
 

Wash temperature	165°F (74°C)
------------------	--------------
- c) Single-tank, conveyor machine:
 

Wash temperature	160°F (72°C)
------------------	--------------
- d) Multi-tank, conveyor machine:
 

Wash temperature	150°F (66°C)
Pumped rinse temperature	160°F (72°C)
- e) Single-tank, pot, pan, and utensil washer (either stationary or moving rack)
 

Wash temperature	140°F (60°C)
------------------	--------------

9. Mechanical Warewashing Equipment, Hot Water Sanitization Temperatures

In mechanical warewashing machines the temperature of the fresh hot water sanitizing rinse as it enters the manifold may not be more than 194°F (90°C), or less than:

- a) For a stationary rack, single temperature machine, 165°F (74°C); or
- b) For all other machines 180°F (82°C).

10. All warewashing machines shall be thoroughly cleaned daily and as needed to maintain them in a satisfactory operating condition.

11. A warewashing machine shall be provided with an easily accessible and readable data plate affixed to the machine which includes:
  - a) Temperatures required for washing, rinsing, and sanitizing;
  - b) Pressure required for the fresh water sanitizing rinse unless the machine is designed to use only a pumped sanitizing rinse;
  - c) Conveyor speed required for conveyor machines or cycle time required for stationary-rack machines; and
  - d) Required type and concentration of sanitizing solutions.

C. Drying

Unless used immediately after sanitization, all equipment and utensils shall be air-dried. Towel drying shall not be permitted. Utensils that have been air-dried may be polished with cloths which are maintained clean and dry.

**4-404 Food Establishments Without Cleaning Facilities**

Retail food establishments that do not have facilities for proper cleaning and sanitizing of utensils and equipment shall not prepare food, package food, or dispense unpackaged food other than whole, uncut raw fruits, raw vegetables, and whole nuts in the shell.

**4-405 Food-Contact Surfaces of Equipment and Utensils**

A. Equipment food-contact surfaces and utensils shall be clean to sight and touch.

B. Utensils and food-contact surfaces of equipment shall be cleaned and sanitized:

1. Except as specified in paragraph B of this section, before each use with a different type of raw animal food, such as beef, fish, lamb, pork, or poultry;
2. Each time there is a change from working with raw animal foods to working with ready-to-eat foods;
3. Between uses with raw fruits or vegetables and with potentially hazardous food;
4. At any time during the operation when contamination may have occurred; and
5. After final use each working day.

\*C. Where equipment and utensils are used for the preparation of potentially hazardous foods on a continuous or production-line basis, utensils and the food-contact surfaces of equipment shall be cleaned and sanitized at intervals not to exceed four (4) hours. Utensils and equipment used to prepare food in a refrigerated room or area that is maintained at one of the temperatures in Figure 3 and the utensils and equipment are cleaned at the frequency in the following figure that corresponds to the temperature:

<u>Temperature</u>	<u>Cleaning Frequency</u>
41°F (5.0°C) or less	24 hours
>41°F - 45°F (>5.0°C - 7.2°C)	20 hours
>45°F - 50°F (>7.2°C - 10.0°C)	16 hours
>50°F - 55°F (>10.0°C - 12.8°C)	10 hours

D. The food-contact surfaces of cooking devices, baking equipment and the cavities and door seals of microwave ovens shall be cleaned at least every 24 hours . This shall not apply to hot-oil cooking equipment and hot-oil filtering systems. The food-contact

surfaces of all cooking equipment shall be kept free of encrusted grease deposits and other accumulated soil.

#### **4-406 Nonfood-Contact Surfaces**

Nonfood-contact surfaces of equipment, including transport vehicles, shall be cleaned as often as necessary to keep the equipment free from the accumulation of dust, dirt, food particles, and other debris.

#### **4-407 Dry Equipment Cleaning Methods**

Dry equipment cleaning methods, such as brushing, scraping, and vacuuming shall contact only surfaces that are soiled with dry food residues that are not potentially hazardous; this cleaning equipment shall not be used for any other purpose.

### **4-5 LAUNDRY FACILITIES**

#### **4-501 Laundry Facilities**

- A. If provided, laundry facilities shall be restricted to the washing and drying of linens and work clothes used in the operation. If such items are laundered on the premises, an electric or gas dryer shall be provided and used, except that it is not necessary to provide an electric or gas clothes dryer given that:
  - 1. On-premise laundering is limited to wiping cloths intended to be used moist, and
  - 2. The laundered wiping cloths are stored in an approved sanitizing solution; or
  - 3. The laundered wiping cloths are air-dried in a laundry room or other approved locations.
- B. Laundry facilities shall not be located in food preparation areas. If located in food storage areas, it shall be operated in a manner that prevents the contamination of food, equipment, utensils, linens, single-service and single-use articles and wiping cloths.
- C. Soiled linens shall be kept in clean, nonabsorbent receptacles or clean, washable laundry bags. Soiled linens shall be stored and transported to prevent contamination of food, clean equipment, clean utensils, single-service and single-use articles.

### **4-6 EQUIPMENT AND UTENSIL HANDLING AND STORAGE**

#### **4-601 Equipment and Utensil Storage**

- A. Cleaned and sanitized equipment and utensils shall be handled in a way that protects them from contamination. Spoons, knives, and forks shall be touched only by their handles. Cups, glasses, bowls, plates, and similar items shall be handled without contact with inside surfaces or surfaces that contact the user's mouth.
- B. Cleaned and sanitized utensils and equipment shall be stored at least 6 inches (15.24 cm) above the floor in a clean, dry location in a way that protects them from contamination by splash, dust, and other means. The food-contact surfaces of fixed equipment shall also be

protected from contamination. Equipment and utensils shall not be placed under sewer lines or water lines that are not protected to intercept potential drips, including leaking automatic fire protection sprinkler heads, or under lines on which water has condensed.

- C. Utensils shall be air-dried before being stored or shall be stored in a self-draining position.
- D. Glasses and cups shall be stored inverted. Other stored utensils shall be covered or inverted, wherever practical. Facilities for the storage of knives, forks and spoons shall be designed and used to present the handle to the employee or consumer. Unless tableware is pre-wrapped, holders for knives, forks and spoons at self-service locations shall protect these articles from contamination and present the handle of the utensil to the consumer.

#### **4-602 Single-Service and Single-Use Articles**

- A. Single-service articles shall be stored at least 6 inches (15.24 cm) above the floor in closed cartons or containers which protect them from contamination. They shall not be placed under exposed sewer lines or water lines, except for automatic fire protection sprinkler heads that may be required by law.
- B. Single-service articles shall be handled and dispensed in a manner that prevents contamination of surfaces which may come in contact with food or with the mouth of the user.
- C. Single-service knives, forks, and spoons packaged in bulk shall be inserted into holders or be wrapped by employees who have washed their hands immediately prior to sorting or wrapping the utensils. Unless single-service knives, forks, and spoons are pre-wrapped or prepackaged, holders shall be provided to protect these items from contamination and present the handle of the utensil to the consumer.
- D. Single-service and single-use articles may not be reused.
- E. Mollusk and crustacea shells may not be used more than once as serving containers.

#### **4-603 Preset Tableware**

Tableware may be preset if:

- A. It is protected from contamination by being wrapped, covered or inverted;
- B. It is exposed and unused settings are removed when a consumer is seated; or
- C. It is exposed and unused settings are cleaned and sanitized before further use, if the settings are not removed when the customer is seated.

## CHAPTER 5

### WATER, PLUMBING, AND WASTE

#### 5-1 WATER SUPPLY

##### \*5-101 General

- A. Adequate, uncontaminated, safe potable water for the needs of the retail food establishment shall be provided from a source constructed, maintained, and operated according to the *Colorado Primary Drinking Water Regulations* and regulations adopted pursuant to Title 25-1.5-203 C.R.S., or
1. If the retail food establishment does not meet the definition of a public water system pursuant to article 1.2.2(48) of the *Colorado Primary Drinking Water Regulations*, the retail food establishment shall provide adequate treatment on a continuous basis and bacteriological samples at a minimum of once per quarter or at a frequency determined by the Department and;
  2. Retail food establishments with water supplies determined to be surface water or under the influence of surface water shall be required to filter their water to 1 $\mu$ m (micron) using National Sanitation Foundation approved equipment to ensure inactivation and/or removal of giardia and viruses, and maintaining a residual disinfectant concentration.

##### \*5-102 System Flushing and Disinfection

A drinking water system shall be flushed and disinfected before being placed in service after construction, repair, or modification and after an emergency situation, such as a flood, that may introduce contaminants to the system.

##### \*5-103 Bottled Drinking Water

Bottled drinking water used or sold in a retail food establishment shall be obtained from approved sources in accordance with Processing and Bottling of Bottled Drinking Water, 21 CFR §129, (2003).

##### \*5-104 Transportation

All potable water not provided directly by pipe to the retail food establishment from the source shall be transported in a bulk water transport system and shall be delivered to a closed-water system. Both of these systems shall be constructed and operated according to law.

##### \*5-105 Non-Potable Water

A non-potable water system is permitted for air conditioning, equipment cooling, and fire protection, and shall be installed according to law. Non-potable water shall not directly or indirectly contact food or equipment or utensils that contact food. The piping of any non-potable

water system shall be identified so that it is readily distinguishable from piping that carries potable water.

**\*5-106 Pressure and Temperature**

Water under pressure of at least 15 pounds per square inch (psi) (1.05 kg per sq. cm) at the required temperature shall be provided to all fixtures and equipment that use water.

**\*5-107 Hot Water**

Hot water generation and distribution systems shall be sufficient to meet the peak hot water demands throughout the retail food establishment. (see Appendix D)

**\*5-108 Steam**

Steam used in contact with food or food-contact surfaces shall be free from any unsafe materials or additives not listed in Specific Usage Additives, 21 CFR §173.310, (2003) (see Appendix E).

**5-2 PLUMBING SYSTEM**

**5-201 General**

Plumbing shall be sized, installed, and maintained in accordance with applicable state and local plumbing codes, ordinances, regulations, and standards. There shall be no unprotected cross-connection between the potable water supply and any non-potable water supply, nor any sources of contamination. Plumbing shall be designed and constructed according to the 2000 Uniform Plumbing Code. Where local building departments have adopted codes equivalent or more stringent than the above, those codes shall apply.

**\*5-202 Backflow**

A. General

The potable water system shall be constructed to prevent backflow. Devices or assemblies shall be installed to prevent backflow at all fixtures or appliances. Inlets to tanks, vats, garbage disposals, troughs, fixtures and equipment with submerged inlets shall be protected by an approved vacuum breaker located on the discharge side of the last valve not less than 6 (six) inches (154.4 mm) above the overflow rim of such equipment, or with an approved air gap at the inlet. Where utilized, an air-gap separation shall be a minimum vertical distance of twice the potable water outlet diameter between the outlet and the fixture's flood level rim, but shall not be less than 1 inch (25.4mm). No hose shall be attached to a potable water outlet that is not equipped with a suitable backflow prevention device. Backflow prevention devices or assemblies shall be installed for service and maintenance access. Any discharge from a backflow preventer shall be visible and discharged indirectly to the sanitary sewer.

B. Backflow Prevention Device, Carbonator

The potable water supply to carbonated beverage dispensers shall be protected from backflow by at least one of the following methods:

1. An approved air gap; or
2. A vented and screened dual check valve constructed of stainless steel or other material impervious to attack by carbonated water, specifically designed to control the backflow of carbonated water from a soda carbonator, and installed downstream of any copper or copper alloy pipe or fixture; or
3. A reduced pressure zone backflow prevention assembly constructed of stainless steel or other material impervious to attack by carbonated water.

**5-203 Conditioning Device, Design**

A water filter, screen, and other water conditioning device installed on water lines shall be designed and located to facilitate disassembly for periodic servicing and cleaning. A water filter element shall be of the replaceable type.

**5-204 Grease Trap / Grease Interceptor**

If required by the local building, water or sanitation authority, when possible, a grease trap or grease interceptor should be located outside the establishment. When installed inside the establishment, a grease trap or grease interceptor shall be located away from the food preparation area and be easily accessible for cleaning.

**5-205 Garbage Grinders**

- A. In new or extensively remodeled retail food establishments, garbage grinders and/or disposers, if used, shall be installed at the warewashing or food preparation sink, warewashing machine, or as an isolated unit. The installation will be approved under the following conditions: Shall not be installed in the basin of a sink;
- B. Shall be directly connected to the sanitary sewer; or
- C. If installed in the drainboard of a food preparation sink, the drainboard shall be equipped with an indirectly drained scupper/scrap basket or similar device to prevent contamination of food-contact surfaces. A second approved eighteen inches (18") (46 cm) self-draining drain board or alternate approved methods shall be provided to prevent cross-contamination of food.

**\*5-206 Drainage Of Equipment.**

- A. Warewashing machines, refrigerators, warewashing sinks, food/vegetable preparation sinks, steam kettles, potato peelers, ice bins and ice machines, and similar types of equipment in which food, portable equipment or utensils are placed shall be indirectly connected to the waste line and shall drain into an approved receptor of such size, shape, and capacity to prevent splashing or flooding. The receptor shall be readily accessible for cleaning and inspection.
- B. Warewashing sinks and dishmachines may be directly connected to the plumbing waste system provided there is a floor drain or floor sink installed within 5 feet (1.5 M) immediately downstream of the sink waste line, and the fixture shall be connected on the sewer side of the floor drain or floor sink, and no other fixtures are connected to the

waste line. The fixture and floor drain shall be trapped and vented as required by the 2000 Uniform Plumbing Code or where local building departments have adopted codes equivalent or more stringent than the above, those codes shall apply (see Figure3).

- C. In new or extensively remodeled food establishments, each walk-in refrigerator used for iced products, hanging meats or which requires flushing shall either be equipped with a floor drain installed only with indirect waste and discharged through an air gap into an approved receptor or constructed so all parts of the floor of such walk-in refrigerator shall be graded to drain to the outside of the refrigerator through a waste pipe, doorway or other opening.

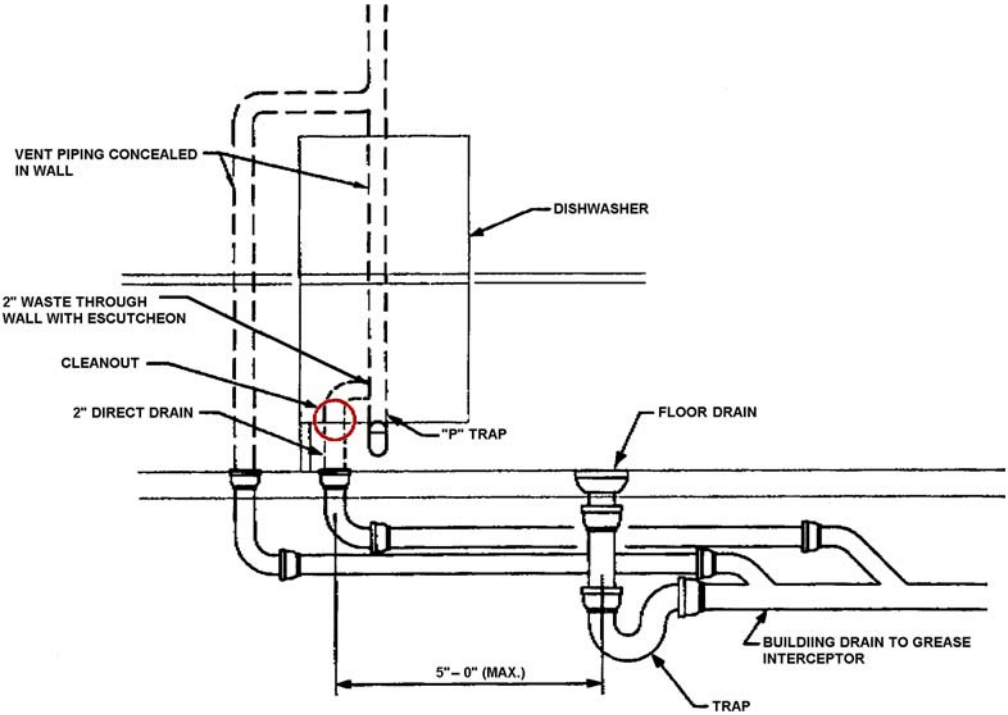

**FIGURE 3**

**5-207 Drainage System Installation**

Drain lines from equipment shall not discharge wastewater in a manner that permits the flooding of floors, or the flowing of water across working or walking areas, or into difficult-to-clean areas that create a nuisance.

## 5-208 Handwashing Lavatory, Water Temperature, and Flow

- \*A. Fixtures. The number of fixtures shall comply with the requirements of the plumbing code adopted by the respective local jurisdiction, or in the absence of such local requirements with the minimum plumbing fixtures listed in the 2000 Uniform Plumbing Code, table 4-1.
- \*B. Accessibility. Handsinks shall be conveniently located to employees involved in food and utensil handling. Handsinks shall be unobstructed and accessible to employees at all times and used only for handwashing. Sinks used for food preparation or for washing equipment shall not be used for handwashing. Handsinks used for toilet rooms shall be located in the toilet rooms.
- \*C. Lavatory Facility Faucets. Each handsink shall be provided with hot (minimum of 90°F [35°C]) and cold water tempered by means of a mixing valve or combination faucet. Any self-closing, slow-closing, or metering faucet used shall be designed to provide a flow of water for at least 15 seconds without the need to reactivate the faucet. Steam mixing valves are prohibited at handsinks.
- D. \*A supply of hand-cleansing soap or detergent shall be available at each handsink. \*A supply of dispensed sanitary towels, disposable towels, or a hand-drying device providing heated air shall be conveniently located near each handsink. \*Common towels are prohibited. If disposable towels are used, easily cleanable waste receptacles shall be conveniently located near the handsinks.
- E. Handsinks, soap dispensers, hand-drying devices and all related fixtures shall be kept clean and in good repair.

## 5-209 Toilets and Urinals

- \*A. Toilet facilities shall be installed according to law, shall be the number required by law, shall be conveniently located, and shall be accessible to employees and patrons.
- B. Separate toilet facilities shall be required for each sex in establishments with seating capacity in excess of 15 patrons or more than 15 employees. In all new or extensively remodeled retail food establishments, these facilities shall be installed to comply with the requirements of the Plumbing Code adopted by the respective local jurisdictions, or in the absence of such local requirements, with the minimum numbers of plumbing fixtures listed in the 2000 Uniform Plumbing Code, table 4-1.
- C. Separate toilet facilities are not required for each sex in places of 15 or fewer seating capacity for patrons, or 15 or fewer employees where there is no seating capacity, provided the toilet is a single occupancy facility and the door can be secured from the inside.  
  
If a separate men's toilet room is installed and it is a single occupancy toilet room, unless otherwise required by the local jurisdiction, a urinal is not required if the total seating capacity does not exceed 100.
- D. Retail food establishments with no space on the premises for consumption of food by patrons are required to provide toilet facilities only for employees. Patron facilities shall

be available where parking is provided primarily for consumption of food on the premise. In all new or extensively remodeled retail food establishments where parking is provided primarily for consumption of food on the premise, the number of necessary fixtures shall comply with the minimum plumbing fixtures required by the Plumbing Code adopted by the respective local jurisdiction, or in the absence of such local requirements, with the numbers listed in the 2000 Uniform Plumbing Code, table 4-1.

- E. Employees and patrons may use the same toilet facility provided that patrons have access to them without entering the food preparation, food storage, or warewashing or utensil storage areas of the establishment.
- F. Public toilets in multiple activity areas such as shopping centers, sports centers, etc., may suffice for the use of retail food establishment patrons and employees, if fixtures are provided in adequate numbers conveniently located to the retail food establishment and available at all times the retail food establishment is in operation.
- G. Toilet facilities, including toilet fixtures and any related vestibules, shall be kept clean and in good repair. A supply of toilet tissue in a permanently mounted dispenser shall be provided at each toilet at all times. Easily cleanable receptacles shall be provided for waste materials.

Receptacles shall be emptied at least once a day, and more frequently when necessary to prevent excessive accumulation of waste material.

#### **5-210 Utility Facility**

- A. In new or extensively remodeled retail food establishments, at least one conveniently located utility sink or curbed cleaning facility with a floor drain and hot and cold water shall be provided and used for the cleaning of mops or similar wet floor cleaning tools and for the disposal of mop water or similar liquid wastes.
- B. Suitable cleaning equipment and supplies, such as high pressure pumps, hot water, steam, and detergent, shall be provided as necessary for effective cleaning of equipment and receptacles for refuse, recyclables, and returnables. If approved by the regulatory authority, off-premise cleaning services may be used.
- \*C. A utility sink cannot be used for food preparation or warewashing. A utility sink cannot be used for handwashing in new or extensively remodeled retail food establishments.

#### **\*5-211 Sewage**

All sewage shall be disposed of by a sewage disposal system constructed, maintained and operated according to law.

#### **\*5-212 Water Reservoir of Fogging Devices, Cleaning**

- A. A reservoir used to supply water to a device, such as a produce fogger shall be:
  - 1. Installed and maintained in accordance with manufacturer's specifications; and
  - 2. Cleaned in accordance with manufacturer's specifications or according to the procedures specified in Paragraph B of this section, whichever is more stringent.

- B. Cleaning procedures shall include at least the following steps and shall be conducted at least once a week:
  - 1. Draining and complete disassembly of the water and aerosol contact parts;
  - 2. Brush-cleaning the reservoir, aerosol tubing, and discharge nozzles with a suitable detergent solution;
  - 3. Flushing the complete system with water to remove the detergent solution and particulate accumulation; and
  - 4. Rinsing by immersing, spraying, or swabbing the reservoir, aerosol tubing, and discharge nozzles with at least 50 ppm (mg/L) hypochlorite solution.

### **5-3 REFUSE, RECYCLABLES, AND RETURNABLES**

#### **5-301 Containers**

- A. Garbage and refuse shall be held in durable, easily cleanable containers that do not leak and do not absorb liquids. Plastic bags and/or wet strength paper bags shall be used to line these containers. Such bags and durable plastic garbage and refuse containers shall be used for storage inside the food establishment.
- B. Containers stored in food preparation and utensil washing areas shall be emptied when full.
- C. Containers stored outside the food establishment, including dumpsters, compactors, and compactor systems, shall be easily cleanable, shall be insect and rodent-proof, shall be provided with tight-fitting lids, doors, or covers, and shall be kept covered when not in actual use. Containers designed with drains, drain plugs shall be in place at all times, except during cleaning.
- D. There shall be a sufficient number of containers to hold all the garbage and refuse that accumulates.
- E. Soiled containers, including dumpsters, compactors, and compactor systems, shall be cleaned at a frequency to prevent insect and rodent attraction. Each container shall be thoroughly cleaned on the inside and outside in a way that does not contaminate food, equipment, utensils, or food preparation areas. Suitable facilities, detergent, and hot water or steam, shall be provided and used for cleaning containers. Liquid waste from compacting or cleaning operations shall be disposed of as sewage.

#### **5-302 Storage**

- A. Garbage and refuse, on the premises, shall be stored in a manner to be inaccessible to insects and rodents. Cardboard or other packaging material not containing garbage or food wastes need not be stored in covered containers provided such materials do not create a nuisance.
- B. Garbage or refuse storage rooms and recycling areas if provided, shall be constructed of easily cleanable, nonabsorbent, washable materials, shall be kept clean, and shall be

insect and rodent resistant. These areas shall be large enough to store all garbage and refuse containers.

- C. Outside storage areas or enclosures, if provided, shall be kept clean and shall be large enough to store all the garbage and refuse containers. Garbage and refuse containers, dumpsters, and compactor systems located outside, shall be stored on a smooth surface of nonabsorbent material, such as concrete or machine-laid asphalt, that is kept clean and maintained in good repair.

**5-303 Disposal**

- A. Garbage, refuse and recyclable materials shall be removed often enough to prevent the development of objectionable odors and the attraction of insects and rodents.
- B. Where garbage or refuse is burned on the premises, it shall be done by controlled incineration in accordance with the law. Areas around incineration units shall be kept clean and orderly.

**5-304 Storage Areas, Redeeming Machines, Equipment, and Receptacles, Location**

- A. An area designated for refuse, recyclables, returnables and, a redeeming machine for recyclables or returnables, except as specified in Paragraph B of this section, shall be located separate from food, equipment, utensils, linens, and single-service and single-use articles, and a public health nuisance is not created.
- B. A redeeming machine may be located in the packaged food storage area or consumer area of a retail food establishment if food, equipment, utensils, linens, and single-service and single-use articles are not subject to contamination from the machines and a public health nuisance is not created.
- C. The location of equipment and receptacles for refuse, recyclables and returnables may not create a public health nuisance or interfere with the cleaning of adjacent space.

## **CHAPTER 6**

### **PHYSICAL FACILITIES**

#### **6-1 FLOORS**

##### **6-101 Floor Construction**

- A. Floors and floor coverings in all food preparation, food storage, warewashing areas, walk-in refrigeration units, dressing rooms, locker rooms, utility sink areas, toilet rooms, garbage rooms, and around permanently installed buffets, salad bars and soft drink dispensers shall be constructed of smooth, durable, nonabsorbent material and shall be maintained in good repair. Areas subject to spilling or dripping of grease or fatty substances shall be of grease-resistant material. Nothing in this section shall prohibit the use of anti-slip floor coverings in areas where necessary for safety reasons.
- B. Floors which are water flushed or which receive discharges of water or other fluid wastes or are in areas where pressure spray methods for cleaning are used, shall be provided with properly installed trapped drains and graded to drain. In all new establishments, floor drains and floor sinks shall be installed to be accessible for cleaning.

##### **6-102 Floor Carpeting**

Carpeting, if used as a floor covering, shall be of closely-woven construction, properly installed, easily cleanable, and maintained in good repair. Carpeting shall not be used in food preparation, warewashing, food storage, utility sink areas, or in toilet room areas where urinals or fixtures are located. Carpeting is permitted in the retail sales area provided it is maintained in good repair and kept clean.

##### **6-103 Utility Line Installation**

Exposed utility service lines and pipes shall be installed in a way that does not obstruct or prevent cleaning of the floor. In all new or extensively remodeled food establishments, installation of exposed horizontal utility service lines and pipes on the floor is prohibited.

##### **6-104 Floor Junctures**

All floors installed in food preparation, food storage and warewashing areas, and in walk-in refrigerators, dressing or locker rooms, utility sink areas, and toilet rooms, shall provide a coved juncture between the floor and wall. In all cases, the juncture between the floor and wall shall be closed and sealed.

##### **6-105 Prohibited Floor Covering**

Cardboard, newspapers, sawdust, wood shavings, granular salt, baked clay, diatomaceous earth, or similar materials shall not be used as floor coverings; however, these materials may be used in amounts necessary for immediate spot clean-up of spills or drippage on floors.

**6-106 Mats and Duckboards**

Mats and duckboards shall be designed to be removable, easily cleanable, and maintained in good repair.

**6-2 WALLS AND CEILINGS**

**6-201 Construction**

- A. Walls, wall coverings, and ceilings shall be designed, constructed and installed to be smooth and easily cleanable.
- B. Except for in dry storage units, walls, including non-supporting partitions, wall coverings and ceilings of walk-in refrigerating units, food preparation areas, food storage areas, equipment-washing and warewashing areas shall be smooth, nonabsorbent, easily cleanable, and maintained in good repair. Concrete or pumice blocks used for interior wall construction in these locations shall be finished and sealed to provide an easily cleanable surface. Acoustical material, free of porous perforations, smooth and durable enough to be washed with a cloth or sponge, may be used. Walls, including non-supporting partitions and wall coverings in toilet rooms shall be smooth, nonabsorbent, and easily cleanable. Porous acoustical ceilings are permitted in toilet rooms and their vestibules.

**6-202 Attachments, Exposed Construction**

- A. Except as specified in Paragraph C of this section, attachments to walls and ceilings such as light fixtures, mechanical room ventilation system components, vent covers, wall-mounted fans, decorative items, and other attachments shall be easily cleanable.
- B. Studs, joists, and rafters shall not be exposed in those areas listed in section 6-201(B) of these rules and regulations. If exposed in other rooms or areas, they shall be kept clean.
- C. In consumer and backbar areas where limited food preparation occurs, wall and ceiling surfaces and decorative items and attachments that are provided for ambiance need not meet this requirement if they are kept clean.
- D. Exposed utility service lines and pipes shall not obstruct or prevent cleaning of walls and ceilings. Utility service lines or pipes shall not be unnecessarily exposed on walls or ceilings in those areas listed in section 6-201(B) of these rules and regulations.

**6-3 LIGHTING**

**6-301 Light Intensity**

- A. Permanently fixed artificial light sources shall be installed to provide at least 50 foot candles (330 lux) of light on all food preparation surfaces and at warewashing work levels.
- B. Permanently fixed artificial light sources shall be installed to provide, at a distance of 30 inches (76.2 cm) from the floor:

1. At least 20 foot candles (220 lux) of light in sales areas, utensil and equipment storage areas, and in lavatory and toilet areas; and
2. At least 10 foot candles (110 lux) of light throughout walk-in refrigeration units, dry food storage areas, and in all other areas.

**6-302 Light Bulbs, Protective Shielding**

- A. Except as specified in paragraph B of this section, light bulbs shall be shielded, coated, or otherwise shatter-resistant in areas where there is exposed food, clean equipment, utensils, linens, or unwrapped single-service and single-use articles.
- B. Shielded, coated or otherwise shatter-resistant bulbs are not required in areas used only for storing food in unopened packages if:
  1. The integrity of the packages cannot be affected by broken glass falling onto them; and
  2. The packages are capable of being cleaned of debris from broken bulbs before the packages are opened.
- C. An infrared or other heat lamp shall be protected against breakage by a shield surrounding and extending beyond the bulb so that only the face of the bulb is exposed.

**6-4 OPERATION AND MAINTENANCE**

**6-401 Cleaning Physical Facilities**

- A. Cleaning of floors, walls, and ceilings shall be done as needed, preferably during periods when the least amount of food is exposed, such as after closing.
- B. Only dustless methods for cleaning floors, walls, and ceilings shall be used, such as vacuum cleaning, wet cleaning, treated dust mops, or the use of dust-arresting sweeping compounds with brooms.
- C. Floors, mats, duckboards, walls, ceilings, and attachments (e.g., light fixtures, vent covers, wall and ceiling mounted fans, and similar equipment), and decorative materials (e.g., signs and advertising materials), shall be kept clean. Mop water shall be changed frequently.

**6-402 Cleaning Equipment Storage.**

Maintenance and cleaning tools, such as brooms, mops, vacuum cleaners, and similar equipment, shall be maintained in good repair and stored in a way that does not contaminate food, utensils, equipment, or linens. Maintenance and cleaning tools shall be stored in an orderly manner to facilitate the cleaning of the storage area.

## **6-5 PREMISES**

### **6-501 General**

- A. Retail food establishments and all parts of the property used in connection with operations of the retail food establishment shall be kept free of litter and shall comply with local ordinances.
- B. The outdoor walking and driving areas shall be surfaced with concrete, asphalt, gravel or other materials that have been effectively treated to minimize dust, facilitate maintenance, and minimize muddy conditions. These surfaces shall be graded to drain and kept free of litter. Exterior surfaces of buildings shall be of weather-resistant materials and shall comply with law.
- C. Only articles necessary to the operation and maintenance of the retail food establishment shall be stored on the premises.

### **6-502 Living Areas**

No retail food establishment operation shall be conducted in any area used as living or sleeping quarters. A retail food establishment operation shall be separated from any living or sleeping quarters by complete partitioning and solid, self-closing doors, and shall comply with local requirements.

## CHAPTER 7

### POISONOUS OR TOXIC MATERIALS

#### 7-1 LABELING AND IDENTIFICATION

##### \*7-101 Identifying Information, Prominence

Containers of poisonous or toxic materials and personal care items shall bear a legible manufacturer's label.

##### \*7-102 Name

Working containers used for storing poisonous or toxic material, such as cleaners and sanitizers taken from bulk supplies, shall be clearly and individually identified with at least the name of the material.

##### \*7-103 Separation

Poisonous or toxic materials shall be stored so they do not contaminate food, equipment, utensils, linens, or single-service and single-use articles by:

- A. Separating the poisonous or toxic materials by spacing or partitioning; and
- B. Locating the poisonous or toxic materials in an area that is not above food, equipment, utensils, linens, and single-service or single-use articles. Except that equipment and utensil cleaners and sanitizers may be stored in warewashing areas for availability and convenience if such materials are stored to prevent contamination of food, equipment, utensils, linens, or single-service and single-use articles.
- C. Poisonous or toxic materials stored or displayed for retail sale shall be separated from food and single-service articles by spacing, partitioning, or dividers. These materials shall not be stored or displayed above food or single-service articles.

##### \*7-104 Restriction

- A. Only those poisonous or toxic materials required for the operation and maintenance of a retail food establishment, such as for the cleaning and sanitizing of equipment and utensils and the control of insects and rodents, shall be allowed in a retail food establishment.
- B. Paragraph A of this section does not apply to packaged poisonous or toxic materials that are for retail sale.

##### \*7-105 Use of Materials

- A. Sanitizers, cleaning compounds, or other compounds intended for use on food-contact surfaces shall not be used in a way that leaves a toxic residue on such surfaces.

- B. Poisonous or toxic materials shall not be used in a way that contaminates food, equipment or utensils, nor in a way other than in full compliance with the manufacturer's labeling.

**\*7-106 Food Containers**

A container previously used to store poisonous or toxic materials shall not be used as a food contact surface. A container previously used to store food shall not be used as a container to store toxic materials.

**\*7-107 Chemicals for Washing Fruits and Vegetables, Criteria**

Chemicals used to wash whole fruits and vegetables shall meet the requirements of Chemicals Used In Washing Or To Assist In The Lye Peeling Of Fruits And Vegetables, 21 CFR §173.315, (2003).

**\*7-108 Boiler Water Additives, Criteria**

Chemicals used as boiler water additives shall meet the requirements specified in Boiler Water Additives, 21 CFR §173.310, (2003) (see Appendix E).

**\*7-109 Drying Agents, Criteria**

Drying agents used in conjunction with sanitization shall be approved by the Department.

**\*7-110 Personal Medications**

Only those medications necessary for the health of employees shall be present in the retail food establishment. Medications and cosmetics shall be stored in properly labeled containers and located so that food and food-contact surfaces of equipment, utensils, linens, single-service and single-use articles cannot be contaminated. Medications requiring refrigeration and stored in a food refrigerator shall be properly identified, double packaged and located on the lowest shelf. This paragraph does not apply to medications that are stored or displayed for retail sale.

**\*7-111 First Aid Supplies**

First aid supplies shall be properly labeled and stored in a way that prevents them from contaminating food and food-contact surfaces, equipment, utensils, linens, single-service and single-use articles.

## CHAPTER 8

### INSECT, RODENT AND ANIMAL CONTROL

#### 8-1 PREVENTION

##### 8-101 Outer Openings, Protected

- A. Openings to the outdoors shall be protected against the entry of insects and rodents by:
  - 1. Closed, tight-fitting windows; and
  - 2. Solid self-closing, tight-fitting doors; or
- B. If windows or doors are kept open, the openings shall be protected against the entry of insects and rodents by:
  - 1. 16 mesh to 1 inch (16 mesh to 25.4 mm) screens,
  - 2. Properly designed and installed air curtains to control flying insects, or
  - 3. Other effective means.
- C. Paragraph B of this section does not apply in customer areas if flying insects and other pests are absent due to the location of the retail food establishment, the weather, or other limiting conditions.
- D. Doors used only for delivery or emergency exit are not required to be equipped with self-closing devices, but shall remain closed at all other times.
- E. All foundations shall be rodent-proof. Openings between the floor and bottom of outer doors, when closed, shall be no greater than one-fourth inch (1/4") (0.635 cm).

##### \*8-102 Controlling Pests

- A. Insects, rodents, and other pests shall be controlled as specified in Paragraph B of this section to minimize their presence:
  - 1. Within the physical facility and its contents; and
  - 2. On the contiguous land or property under the control of the retail food establishment generator.
- B. The presence of insects, rodents, and other pests shall be controlled by:
  - 1. Routinely inspecting the premises for evidence of pests;
  - 2. Using methods, if pests are found, such as trapping devices or extermination.
  - 3. Eliminating harborage conditions.

##### 8-103 Insect Control Devices, Design and Installation

- A. Devices used to electrocute flying insects and that may impel insects or insect fragments shall be:

1. Designed to have escape-resistant trays; and
2. Installed so that:
  - a) The devices are not located over a food preparation area; and
  - b) Dead insects and insect fragments are prevented from falling on or being impelled onto exposed food, clean equipment, utensils, linens, and unwrapped single-service and single-use articles.
- B. Devices used to trap insects by adherence may not be installed above exposed food, clean equipment, utensils, linens, or unwrapped single-service and single-use articles unless the device is designed to completely contain the trapped insects.

**\*8-104 Pesticide Application**

- A. Only pesticides registered for application in a food establishment are permitted and shall be applied according to label directions.
- B. A pesticide shall be applied so that direct or indirect contact with food, equipment, utensils, linens, and single-service and single-use articles is prevented by protecting those items as follows:
  1. Removing the items;
  2. Covering the items with impermeable covers; or
  3. Taking other appropriate preventive actions; and
  4. Cleaning and sanitizing equipment and utensils after the application of a pesticide.
- C. Bait shall be contained in a covered tamper-proof bait station.
- D. Tracking powders may not be used in a retail food establishment.

**\*8-105 Removing Birds, Insects, Rodents, and Other Pests**

Birds, insects, rodents, and other pests shall be removed from control devices and the premises at a frequency that prevents their accumulation, decomposition, or the attraction of pests.

**\*8-106 Prohibiting of Animals**

- A. \*Live animals shall be excluded from within the food establishment. This exclusion does not apply to edible fish, crustacea, shellfish or fish in aquariums. Live or dead fish bait shall be stored separately from food or food products.  
  
\*Patrol dogs accompanying security or police officers shall be permitted in offices, storage areas and outside storage areas and outside establishment premises. \*Sentry dogs may be permitted to run loose in outside fenced areas for security reasons. Guide and service animals accompanying blind, visually handicapped, partially deaf or otherwise disabled persons or animals training for this purpose shall be permitted in customer and office areas.

- \*B. While on duty, persons employed in the food operational areas of a retail food establishment shall not care for or handle any pets, or patrol/sentry dogs.

## CHAPTER 9

### MOBILE RETAIL FOOD ESTABLISHMENTS OR PUSHCARTS

#### 9-1 MOBILE RETAIL FOOD ESTABLISHMENT

##### 9-101 General

Mobile retail food establishments or pushcarts shall comply with the requirements of these rules and regulations except as otherwise provided in this chapter. The Department may impose additional requirements to protect against health hazards related to the conduct of the mobile retail food establishment and may prohibit the sale of any potentially hazardous foods. If restrictions are imposed by the Department, they shall be in writing with a copy provided on the mobile unit at all times. A list of menu items prepared and/or served by the operator shall be submitted to the Department.

When no apparent health hazard will result, the Department may waive or modify requirements of this chapter relating to physical facilities, except those requirements of sections 9-104, 9-105, and 9-107 of these rules and regulations. Section 9-107(A) may be waived or modified when operating in accordance to chapter 10 of these rules and regulations.

##### 9-102 Exemptions

Mobile retail food establishments or pushcarts are exempt from requirements for self-contained water or sewage systems, and cleaning and sanitization equipment under the following conditions:

- A. Food is prepared, then packaged in individual servings, transported and stored and served without further handling under conditions meeting the requirements of these rules and regulations; and
- B. Beverages served are not potentially hazardous and are dispensed from covered urns or other protected equipment; and
- C. The required equipment for cleaning and sanitization exists at the commissary.

##### 9-103 Single-service Articles

Mobile retail food establishments or pushcarts shall provide only single-service articles for use by the consumer.

##### \*9-104 Water System

A mobile retail food establishment or a pushcart that does not meet the exemptions of section 9-102 of these rules and regulations shall provide hot and cold potable water under pressure with sufficient capacity for food preparation, utensil cleaning and sanitizing, in accordance with the requirements of these rules and regulations.

The water supply tank shall be designed so that it can be flushed and with a drain that permits complete drainage of the tank. The potable water tank shall have no common interior partition

with the tank holding non-potable water or other liquids. The water tank overflow or vent shall terminate in a downward direction and shall be located and constructed so as to prevent the entrance of contaminants.

The water heater capacity shall be adequate to fill the three-compartment sink with 110°F water without interruptions at a minimum rate of 1 gallon per minute with reserve capacity to provide a minimum of 3 gallons per hour of warm water to all handsinks at all times.

The water inlet shall be located so that it will not be contaminated by waste discharge, road dust, oil, or grease, and it shall be kept capped unless being filled. The water inlet shall be provided with a transition connection of a size or type that will prevent its use for any other service. All water distribution pipes or tubing shall be constructed and installed in accordance with the requirements of these rules and regulations.

When a mobile retail food establishment is connected to a pressurized water supply, it shall be provided with approved backflow prevention devices. This shall include the protection of the water source as well as protection of each individual water service connection.

The water supply hose and couplings shall be of a size and type compatible with the water supply tank inlet fixture and shall be free of cracks and checks. Hose couplings shall be constructed to permit a tight connection between the mobile retail food establishment coupling and the water supply hose bib. Hose ends must be capped, connected or otherwise fully protected when not being used.

#### **9-105 Wastewater Retention**

- \*A. All liquid waste, except drainage from clean potable ice, generated by a mobile retail food establishment or pushcart shall be stored in a retention tank that is at least 15 percent larger than the water supply tank. Liquid waste shall be discharged from the retention tank to an approved sewage disposal system and flushed as often as necessary to maintain sanitary conditions. Discharge onto the surface of the ground shall be strictly prohibited. Drainage from clean potable ice can be discharged onto the surface of the ground provided it does not create a nuisance.
- B. All connections on the vehicle for servicing mobile food unit waste disposal facilities shall be of a different size or type than those used for supplying potable water to the mobile food establishment. The waste connection shall be located lower than the water inlet connection to prevent contamination of the potable water system.
- C. Liquid waste discharge piping and the potable water hose shall not be stored in a manner that may result in cross-contamination.

#### **\*9-106 Handwashing Facilities**

A mobile retail food establishment or pushcart that does not meet all the restrictions of section 9-102 of these rules and regulations must be equipped with a convenient, accessible handsink for employee handwashing. The handsink must be capable of providing a hands-free, continuous flow of warm water. The handsink must be of adequate pressure and size to facilitate proper handwashing. Soap and individual paper towels must also be provided.

**\*9-107 Commissary**

- A. The commissary is considered to be an essential part of the mobile food establishment operation. The commissary shall be constructed and operated in compliance with the requirements of these rules and regulations. Mobile retail food establishments or pushcarts shall operate from a commissary or other fixed retail food establishment and shall report every 24 hours (on operational days) to that location for all supplies and for all cleaning and servicing operations. The mobile retail food establishment operator shall verify to the Department in writing that the mobile unit returns to the commissary every 24 hours.
- B. A mobile retail establishment servicing area shall be provided and shall include a potable water supply. A servicing area is an operating base location to which a mobile food establishment or transportation vehicle returns regularly for such things as vehicle and equipment cleaning, discharging liquid or solid wastes, refilling water tanks and ice bins, and boarding food.
  - 1. Within this servicing area, there shall be a location provided for the flushing and drainage of liquid wastes that is separate from the location provided for potable water servicing and for the loading and unloading of food and related supplies. This servicing area will not be required where only packaged food is placed on the mobile food unit or pushcart, or where mobile food units do not contain waste retention tanks.
  - 2. Potable water servicing equipment shall be installed according to the law and shall be stored and handled to protect the water and equipment from contamination.
  - 3. The mobile retail food establishment liquid waste retention tank shall be thoroughly flushed and drained during the servicing operation. All liquid waste shall be discharged to a sanitary sewage system in accordance with section 5-211 of these rules and regulations.
  - 4. The floor surface of the servicing area shall be constructed of a smooth, nonabsorbent material such as concrete or machine-laid asphalt and shall be maintained in good repair, kept clean, and be graded to drain.
  - 5. The construction of the walls and ceilings of the servicing area is exempt from the provisions of sections 6-201 and 6-202 of these rules and regulations.
- C. A fully equipped, mobile retail food establishment shall not be required to report to a servicing area if:
  - 1. The mobile retail food establishment's potable water system and waste retention system is sufficiently sized or operated properly to serve the needs of the mobile retail food establishment and, and liquid waste is emptied only at service locations approved by the Department; and
  - 2. The mobile retail food establishment is capable of being maintained in a sanitary condition; and
  - 3. Adequate storage areas are provided within the mobile retail food establishment for food, dry goods, single service articles and cleaning supplies; and

4. Adequate facilities are provided for food preparation, for cleaning and sanitizing of equipment and utensils, for the storage of additional food, equipment, utensils and other supplies, and for other servicing operations; and
5. Approved arrangements and facilities are provided and used to supply potable water to the mobile unit for the disposal of wastewater generated by the establishment; and
6. A written operational plan is submitted by the mobile retail food establishment, which demonstrates that this process can be accomplished in compliance with these rules and regulations. Review and approval of this plan must include the menu and standard operating procedures for the mobile unit. Once an operational plan is approved, any additions or changes to the approved plan must be approved by the Department prior to implementation.

**9-108 Additional Requirements**

Spare tires, tools, and other equipment relating to the mechanical operation of the vehicle shall be stored in a way that does not contaminate food, food equipment, or utensils.

## CHAPTER 10

### TEMPORARY RETAIL FOOD ESTABLISHMENTS

#### 10-1 TEMPORARY RETAIL FOOD ESTABLISHMENTS

##### 10-101 General

A temporary retail food establishment shall comply with the requirements of these rules and regulations, except as otherwise provided in this chapter.

A list of menu items used by the operator shall be submitted to the Department. The Department may impose additional requirements to protect against health hazards related to the conduct of the temporary retail food establishment and may prohibit the sale of any potentially hazardous foods. When no apparent health hazard will result, the Department may waive or modify requirements of these rules and regulations.

##### \*10-102 Restricted Operations

Only potentially hazardous foods requiring preparation limited to seasoning and cooking shall be served. The preparation or service of other potentially hazardous foods, including pastries filled with cream or synthetic cream, custards and similar products, salads or sandwiches containing meat, poultry, eggs, or fish, is prohibited unless approved, and adequate equipment and facilities are provided. This prohibition does not apply to any potentially hazardous food prepared and packaged under conditions meeting the requirements of these rules and regulations, obtained in individual servings, stored at a temperature of 41°F (5°C) or below, or at a temperature of 135°F (57°C) or above in facilities that meet the requirements of these rules and regulations, and is served directly in the unopened container in which it was packaged.

##### \*10-103 Ice

Ice that is consumed or that contacts food shall be made under conditions meeting the requirements of these rules and regulations. Ice obtained off site shall be only in chipped, crushed, or cubed form and in single-use safe plastic or wet-strength paper bags filled and sealed at the point of manufacture.

##### 10-104 Equipment

- A. Equipment shall be located and installed to prevent food contamination and to facilitate cleaning the establishment.
- B. Food-contact surfaces of equipment shall be protected from contamination by consumers and other contaminating agents. Effective shields for such equipment shall be provided as necessary to prevent contamination.

##### 10-105 Single-Service Articles

All temporary retail food establishments, which do not have approved facilities for cleaning and sanitizing tableware, shall provide only single-service articles for use by the consumer.

**\*10-106 Water**

A sufficient quantity of potable water shall be available for food preparation and sanitization of food-contact surfaces. The water supply system hoses, piping, and appurtenances must be approved food-contact materials. The water supply system must be installed to preclude the backflow of contaminants into the potable water supply.

**10-107 Wet Storage**

Packaged food may be stored in direct contact with potable ice or potable water if the packaging, wrapping, or container is not subject to entry of water.

**\*10-108 Waste**

All sewage, including liquid waste, shall be disposed of according to law. Drainage from clean potable ice can be discharged onto the surface of the ground provided it does not create a nuisance.

**\*10-109 Handwashing**

A conveniently located handwashing facility shall be available for employee handwashing. This facility must be capable of providing a hands-free, continuous flow of warm water. The handwashing facility must be of adequate pressure and size to facilitate proper handwashing. Soap and individual paper towels must also be provided.

**10-110 Floors**

Floors shall be constructed of concrete, asphalt, tight wood, or other similar material kept in good repair. Dirt or gravel, when graded to drain, may be used as sub-flooring when covered with clean, removable platforms or duckboards, or covered with wood chips, shavings, grass or other suitable materials to control dust.

**10-111 Walls and Ceilings**

- A. Ceilings shall be made of wood, canvas, or other materials that protect the interior of the establishment from the weather. Walls and ceilings shall be constructed in a way that prevents the entrance of insects. Doors to food preparation areas shall be solid or screened and shall be self-closing. Screening material used for walls, doors, or windows shall be at least 16 mesh to the inch (16 mesh to 25.4 mm).
- B. Counter-service openings shall not be larger than necessary for the particular operation conducted. These openings shall be provided with tight-fitting, solid or screened doors or windows, or shall be provided with fans installed and operated to restrict the entrance of flying insects. Counter-service openings shall be kept closed, except when in actual use. Screening of walls, doors and outer openings do not apply if flying insects and other pests are absent due to the location of the establishment, the weather, or other limiting condition.

## **CHAPTER 11**

### **COMPLIANCE PROCEDURES**

#### **11-1 COMPLIANCE**

##### **11-101 General.**

A person shall have a valid retail food establishment license, certificate of license, as defined in section 25-4-1602, C.R.S., or administration and inspection fees pursuant to sections 25-4-1607, C.R.S., to operate a retail food establishment. A person operating a retail food establishment without a valid license, certificate of license or appropriate administration and inspection fees may be prosecuted under sections 16-13-305 and 25-4-1609, C.R.S. Only a person who complies with the requirements of these rules and regulations shall be entitled to receive or retain such a license or certificate. Licenses, certificates, or administration and inspection fees are not transferable. When issued, a valid license or certificate shall be posted in every retail food establishment.

##### **11-102 Issuance of License or Certificate of License.**

- A. Any person desiring to operate a retail food establishment shall make written application for a license or certificate of license or pay administration and inspections fees using forms provided by the Department. Each application form shall include the name and address of each applicant, the location and type of the proposed retail food establishment, and the signature of each applicant.
- B. Prior to approval of an application for a license or certificate of license, the Department shall inspect the proposed retail food establishment to determine compliance with the rules and regulations.
- C. The Department shall approve a license or certificate of license for the applicant if its inspection reveals that the proposed retail food establishment complies with the requirements of these rules and regulations.

##### **11-103 License Renewal.**

The Department may refuse to renew a retail food establishment license or certificate of license for any violation of sections 25-4-1601 et seq., C.R.S., of these rules and regulations, or as otherwise provided by law. This notification shall be presented to license or certificate holders during the last quarter of each calendar year. Denial of a license renewal shall be treated in all respects as a revocation and, hence, procedures for revocation shall be followed. In a case in which the license or certificate holder has made timely and sufficient application for renewal of license, the existing license shall not expire until such application has been finally acted upon by the Department.

##### **11-104 Judicial Review.**

A license or certificate holder adversely affected or aggrieved by a Departmental action may appeal the final action of the Department as provided in section 24-4-106, C.R.S. Suspension or

revocation of a license may be reviewed, upon application for an order in the nature of mandamus or otherwise, by any court of general jurisdiction as provided in section 25-4-1609, C.R.S.

**11-105 Closure Without Suspension.**

Acting under sections 25-1.5-101(1)(a) and 25-1.5-102(1)(a) & (d), C.R.S., the Department, or its authorized representative, shall have the power and duty to close retail food establishments and forbid the gathering of people therein to protect the public health from the cause of epidemic and communicable diseases. Immediate closure shall be used only when the situation imperatively requires emergency action or the operator has been guilty of deliberate and willful violation.

**11-106 Injunctive Relief.**

When serious or repeated violations of these rules and regulations have been found, the Department or its authorized agents may abate the nuisance by seeking injunctive relief through judicial means, as provided under section 16-13-308 and 309, C.R.S.

**11-2 INSPECTIONS**

**11-201 Inspection Frequency.**

- A. An inspection of a retail food establishment shall be performed at least twice every calendar or fiscal year; a seasonal food service establishment shall be inspected once before it opens and at least once while it is in operation; and retail food establishments that operate as grocery stores without a restaurant or deli shall be inspected once every calendar or fiscal year.
- B. The *Colorado Retail Food Establishment Risk-Based Inspectional Frequency Methodology Guidance Document* may be used as a model for an alternative method for determining inspectional frequency. If this model is modified by an agency, the agency must be able to defend the modifications utilizing the public health risk factors contained in the model. The public health risk factors include: 1) food served, 2) operations, 3) weekly meal volume, and 4) inspectional history including critical and non-critical violations.
- C. Additional inspections are to be performed based upon additional assessments of potential risks of foodborne illness including a history of critical violations and numerous or repeat noncritical violations of these rules and regulations; the hazards associated with the particular foods being prepared, stored or served; the method and extent of food storage, preparation and service; and the number and demographic characteristics of the consumers.

**11-202 Access.**

Agents of the Department, after proper identification, shall be permitted to enter any retail food establishment during business hours and at other times during which activity is evident to determine compliance with these rules and regulations. The agents shall be permitted to

examine documents or true copies of documents, excluding prices, that pertain directly to food and supplies purchased, received or used, information pertinent to their HACCP plan, or to persons employed in food and beverage operations when such examination is expected to produce information necessary to protect the public health, enforce these rules and regulations or investigate suspected incidents of foodborne illnesses.

**11-203 Report of Inspections.**

Whenever an inspection of a retail food establishment or commissary is made, the findings shall be recorded on an inspection report form. The inspection report form shall summarize the requirements of these rules and regulations. Inspectional remarks shall describe the violation that exists. A copy of the completed inspection report form shall be furnished by the end of the next workday, following conclusion of the inspection, to the person in charge of the establishment. The completed inspection report form is a public document that shall be made available for public disclosure to any person who requests it according to law.

**11-204 Correction of Violations.**

- A. The inspection report form shall specify a reasonable period of time for the correction of the violations found and correction of the violations shall be accomplished within the period specified, in accordance with the following provisions:
  - 1. If an imminent health hazard exists, such as, but not limited to, complete lack of refrigeration or sewage backup into the establishment, the establishment shall immediately cease food operations. Operations shall not be resumed until authorized by the Department.
  - 2. All critical violations are to be corrected as soon as possible, but in any event, by the date and time specified by the regulatory authority, but in no case to exceed 10 days.
  - 3. All non-critical violations shall be corrected by the date and time agreed to or specified by the regulatory authority based upon the severity of potential health hazards, which could result from the non-critical violation. The regulatory authority is not required to conduct follow-up activities on non-critical violations.
- B. The inspection report shall state that failure to comply with any time limits may result in the initiation of administrative or legal regulatory action. An opportunity for appeal of the inspection findings and time limitation will be provided if a written request for an administrative hearing is filed with the Department within five (5) days following the date of receipt of inspection. If the request for a hearing is received, a hearing shall be held no sooner than twenty (20) days after the operator is notified of the hearing.
- C. Whenever a retail food establishment is required under the provisions of these rules and regulations to cease operations, it shall not resume operations until a re-inspection determines that conditions responsible for the requirement to cease operations no longer exists. Opportunity for re-inspection shall be offered within a reasonable time.

**11-205 Inspection Report.**

The format of an inspection form shall be based upon critical and non-critical categories. The following items must be included:

<b>Item</b>	<b>Category</b>
FOOD SOURCE	CRITICAL
a. Approved source	
b. Wholesome, free of spoilage	
c. Cross-contamination	
d. HACCP plan	
PERSONNEL	CRITICAL
Employee Health	
a. Personnel with infections restricted	
b. Wounds properly covered	
Hygienic Practices	
c. Hands washed as needed	
d. Hygienic practices	
e. Smoking, eating, drinking	
Demonstration of knowledge	
f. Training needed	
FOOD TEMPERATURE CONTROL	CRITICAL
Temperature Control Procedures	
a. Rapidly cool foods to 41° F or less	
b. Rapidly reheat to 165° F or greater	
c. Hot hold at 135° F or greater	
d. Required cook temperature	
e. Cold hold at 41° F or less	
Temperature Control Equipment	
f. Use of Food thermometer (probe-type)	
g. Adequate equipment to maintain food temperatures	
SANITIZATION RINSE	CRITICAL
a. Clean	
b. Temperature	
c. Concentration	
d. Exposure	

<b>Item</b>	<b>Category</b>
<b>WATER, SEWAGE, PLUMBING SYSTEMS</b> a. Safe water source b. Hot and cold water under pressure c. Backflow, backsiphonage d. Sewage disposal	<b>CRITICAL</b>
<b>HANDWASHING FACILITIES</b> a. Adequate number, location b. Accessible c. Soap and drying devices available	<b>CRITICAL</b>
<b>PEST CONTROL</b> a. Evidence of insects or rodents b. Pesticide application c. Animals prohibited	<b>CRITICAL</b>
<b>POISONOUS OR TOXIC ITEMS</b> a. Properly stored b. Properly labeled c. Properly used	<b>CRITICAL</b>
<b>FOOD LABELING , FOOD PROTECTION</b> a. Original container, properly labeled b. Food protected from contamination	<b>NON-CRITICAL</b>
<b>EQUIPMENT DESIGN CONSTRUCTION</b> a. Food-contact surfaces b. Nonfood-contact surfaces c. Dishwashing facilities	<b>NON-CRITICAL</b>
<b>TESTING DEVICES</b> a. Refrigeration units provided with accurate, conspicuous thermometers b. Dishmachines provided with accurate thermometer and gauge cock c. Chemical test kits provided, accessible	<b>NON-CRITICAL</b>
<b>CLEANING OF EQUIPMENT AND UTENSILS</b> a. Food-contact surfaces b. Nonfood-contact surfaces c. Dishwashing operations d. Wiping cloths	<b>NON-CRITICAL</b>

<b>Item</b>	<b>Category</b>
UTENSILS, SINGLE SERVICE ARTICLES a. Utensils provided, used, stored b. Single-service articles stored, dispensed, used c. No reuse of single-service articles	NON-CRITICAL
PHYSICAL FACILITIES a. Plumbing: installed, maintained b. Garbage and refuse c. Floors, walls, ceiling d. Lighting e. Ventilation f. Locker rooms g. Premises maintained h. Separation of living, laundry i. Restroom facilities	NON-CRITICAL
OTHER OPERATIONS a. Personnel: clean clothes, hair restraints, authorized b. Linen properly stored	NON-CRITICAL

### **11-3 EMBARGO AND CONDEMNATION OF FOOD**

#### **11-301 General.**

The power and duty to embargo and condemn food that the Department finds probable cause to believe is in violation of section 3-101 of these rules and regulations has been given to the Department under the statutory authority of sections 25-1.5-104(a) and 25-5-406 et. seg., C.R.S.

#### **11-302 Voluntary Condemnation.**

When the Department finds food that it has probable cause to believe is in violation of section 3-101 of these rules and regulations, the Department shall bring the fact to the attention of the person in charge and request that the food be voluntarily destroyed. If the person in charge agrees to destroy the suspect food, a voluntary condemnation agreement shall be completed and signed. The person in charge shall denature the food under the supervision of the Department. A copy of the voluntary condemnation agreement shall be left with the person in charge.

**11-303 Embargo Placement.**

When the Department finds food that it has probable cause to believe is in violation of section 3-101 of these rules and regulations, the Department shall bring the fact to the attention of the person in charge and request that the food be voluntarily destroyed. Should the person in charge refuse to voluntarily destroy the food, the Department shall embargo the remainder of the food. An embargo notice shall be completed and signed. A copy of the embargo notice shall be left with the person in charge. The remainder of the food product shall be set aside for storage in a container sealed with sampling tape to prevent usage. No person shall remove or dispose of such embargoed article by sale or otherwise.

**11-304 Embargo Release.**

- A. The Department shall complete and sign an embargo release which dictates the subsequent disposition of the product by:
  - 1. Use of the product in the establishment where it was found if demonstrated to be in compliance with section 3-101 of these rules and regulations; or
  - 2. Use of the product by other approved means; or
  - 3. Destruction of the product.
- B. A copy of this release shall be given to the person in charge.
- C. Neither the Department nor the State shall be held liable for damages because of such embargo.

**11-305 Condemnation of Product**

Should the food be found to be not sound or contaminated with filth and a voluntary destruction cannot be obtained, the Department shall petition the court of jurisdiction for seizure and disposition of the food.

**11-4 REVIEW OF PLANS**

**11-401 Submission of Plans**

It shall be necessary to submit to the Department detailed plans and specifications of a proposed newly constructed retail food establishment and or the affected areas of any proposed extensively remodeled retail food establishment. Each retail food operator, or person intending to become a retail food operator, shall be responsible for submitting all plans and specifications. Those assisting an operator may submit plans and specifications on the operator's authority. The Department shall be consulted before preparation of plans and specifications. Approval of both plans and specifications is necessary before construction begins. A minimum of two (2) weeks shall be necessary for the Department to review the plans. Any revision of plans shall be submitted to the Department for review and modification or approval.

#### **11-402 Contents of Plans and Specifications**

Contents of the plans and specifications shall show evidence that the facility complies with applicable portions of these rules and regulations. A plan-view scale drawing of the establishment shall be provided. The plans shall include the location of all retail food equipment, plumbing fixtures and connections, ventilation systems, menu and other pertinent information. A dimensional sketch of the entrance, exits, streets, roadways and alleys shall also be included. Specifications shall be provided on a form supplied by the Department.

#### **11-403 Pre-Operational Inspection.**

Whenever plans and specifications are required by section 11-401 of these rules and regulations to be submitted to the Department, the Department shall inspect the retail food establishment prior to its beginning operation to determine compliance with the approved plans and specifications and with the requirements of these rules and regulations. It shall be necessary to arrange for a pre-opening inspection fourteen (14) days in advance of the date of the intended inspection. For areas of the state without a Local Health Department, it shall be necessary to arrange for a pre-opening inspection twenty-one (21) days in advance of the date of the intended inspection.

### **11-5 PROCEDURE WHEN INFECTION IS SUSPECTED**

#### **11-501 General**

When the Department has reasonable cause to suspect the possibility of disease transmission from any retail food establishment employee, it may secure a morbidity history of the suspected employee or make any other investigation as necessary and shall take appropriate action. The Department may require any or all of the following measures:

- A. The immediate exclusion of the employee from all retail food establishments;
- B. The immediate closing of the retail food establishment concerned until, in the opinion of the Department, no further danger of disease outbreak exists;
- C. Restriction of the employee's services to some area of the establishment where there would be no danger of disease transmission;
- D. Adequate medical and laboratory examination of the employee and other employees.

### **11-6 VARIANCE PROCEDURE**

#### **11-601 Variance Procedure**

- A. Any retail food establishment may request a variance from any requirement of these rules and regulations when such an establishment believes that the requirement results in an undue economic hardship or when it is believed a standard may not apply to the specific situation.
- B. Requests shall be submitted in writing to the Colorado Department of Public Health and Environment and shall include the name and location of the business, the name of the

licensee or prospective licensee when applicable, and the section for which a variance is being requested. This request must be accompanied with a recommendation for approval or denial from the health agency of jurisdiction. Evidence of undue economic hardship should include estimates and costs for compliance. If it is believed that a standard may not apply to the specific situation, an explanation shall be included.

- C. Any person who requests a variance for the provisions of these regulations shall have the burden of supplying the Department with information that demonstrates the conditions exist which warrant the granting of a variance. All doubts shall be resolved in favor of denial.
- D. The Colorado Department of Public Health and Environment may grant a variance if:
  - 1. Such variance is consistent with the purpose and intent of the act and these regulations; and
  - 2. It is consistent with the protection of the public health; and
  - 3. The circumstances of the retail food establishment are unique; and
  - 4. The cost of compliance is so great that it would threaten economic viability of the retail food establishment or the retail food establishment would be in grave jeopardy if compliance were enforced; and
  - 5. The damage to the retail food establishment's economic viability is in fact caused by compliance.
- E. A variance shall expire upon a change of circumstances from those supporting the variance or upon a change of ownership of the retail food establishment.
- F. After review and in circumstances where the Department intends to deny a variance, the Department shall refer the request to an advisory panel of three persons, two persons who represent the retail food industry and a representative from a local health department, to make recommendations to the Department.
- G. Any retail food establishment for which a variance has been denied may appeal such denial by requesting a hearing which will be held in accordance with section 24-4-105 (15), C.R.S.

## **11-7 REFERENCE CITATIONS**

### **11-701 General**

These regulations incorporated by reference (as indicated within) materials originally published elsewhere. Such incorporation does not include later amendments to or editions of the referenced material. The Department maintains certified copies of the complete text of any material incorporated by reference for public inspection during regular business hours and shall provide certified copies of the incorporated material at cost upon request. Information regarding how to obtain or examine the incorporated material is available from the Division Director, Consumer

Protection Division, Colorado Department of Public Health and Environment, 4300 Cherry Creek Drive South, Denver, CO 80246-1530.

Copies of the incorporated materials have been provided to the State Publications Depository and Distribution Center, and are available for interlibrary loan. Any incorporated material may be examined at any State Publications Depository Library.

**11-702 Safe Materials**

The Colorado Pure Food and Drug Law, the Federal Food, Drug and Cosmetic Act and applicable regulations of the U.S. Food and Drug Administration used for the determination of material safety in section 1-202(56) of these rules and regulations may be obtained from the Director of the Consumer Protection Division of the Colorado Department of Public Health and Environment and/or the U.S. Federal Food and Drug Administration.

**11-703 Food Protection Act**

Copies of section 25-4-1601 et seq., C.R.S may be obtained from the Director of the Consumer Protection Division of the Colorado Department of Public Health and Environment.

**11-704 Milk Standards**

Copies of the Grade A Standards referenced in section 3-204 of these regulations may be obtained from the Director of the Consumer Protection Division of the Colorado Department of Public Health and Environment.

**11-705 Ventilation Requirements**

Copies of the (2000) Uniform Mechanical Code or Local Ventilation Codes referenced in section 4-212 of these rules and regulations may be obtained from the International Conference of Building Officials, 503 Alhambra Avenue, Los Angeles, California 90032-3490 or the Local Building Department of jurisdiction, respectively.

**11-706 Code of Federal Regulations**

Copies of the (2003) Code of Federal Regulations referenced in sections 3-211, 4-202, 4-207, 4-403, 5-103, 5-108, 7-107, and 7-108 may be obtained from the Director, Office of the Federal Register, National Archives and Records Administration, Washington DC 20408.

**11-707 Plumbing Requirements**

Copies of the (2000) Uniform Plumbing Code or Local Plumbing Codes referenced in sections 5-201, 5-208, and 5-209 may be obtained from the International Association of Plumbing and Mechanical Officials, 20001 Walnut Drive South, Walnut, California 91789-2825 and/or the Local Building Department of jurisdiction, respectively.

**11-708 Administrative Statutes**

Copies of sections 16-13-305, 306 and 308, C.R.S.; 24-4-106, C.R.S.; 25-1.5-101(1)(a), C.R.S.; 25-1-108 (1)(k), C.R.S.; 25-1-506 (1)(d), C.R.S.; 25-4-401 et seq., C.R.S.; 25-4-1301 et seq., C.R.S.; 25-4-105, C.R.S.; 25-4-1608, C.R.S.; and 25-5-406 (1) and (4) C.R.S., referenced in

sections 3-312, 3-601, 11-101, 11-103, 11-104, 11-105, 11-106, 11-301 and 11-601 of these rules and regulations may be obtained from the Director of the Consumer Protection Division of the Colorado Department of Public Health and Environment.

**11-709 American National Standards Institute (ANSI)**

Copies of the National Sanitation Foundation Standards for food equipment that are classified for sanitation by an American National Standards Institute (ANSI) accredited certification program referenced in section 4-101 of these rules and regulations may be obtained from the Director of the Consumer Protection Division of the Colorado Department of Public Health and Environment.

## ***APPENDIX A - Potentially Hazardous Foods***

"Potentially Hazardous Food" means any food or food ingredient, natural or synthetic, in a form capable of supporting the rapid and progressive growth of infectious or toxigenic microorganisms or the slower growth of C. botulinum.

A food is potentially hazardous: a) if it is of animal origin such as meat, milk, fish, shellfish, edible crustacea, or poultry; or b) if it is of plant origin and has been heat treated; or c) if it is raw seed sprouts. The following is a limited list of specific food products that have been classified to be potentially hazardous.

1. Bacon - If it has not been fully cooked.
2. Balutes - Fertile eggs, generally chicken or duck eggs, which are incubated for a period of time shorter than is necessary for hatching. The developing embryo is incubated generally 14 to 18 days and is considered a delicacy by various ethnic populations when eaten raw or cooked.
3. Beans - All types of cooked beans.
4. Whipped Butter - Hazardous because of the apparent reduced microbiological safety factor created by whipping.
5. Cheese - Soft unripened cheese. Ripened, low moisture hard cheese such as wheels, flats, blocks or longhorns of cheddar cheese produced from pasteurized milk, when waxed or packaged in "shrink" wrapping with the wax or packaging intact, can be safely shipped or stored for a short period of time without refrigeration but it is not recommended. If wheels, flats, blocks, longhorns, or any other forms of cheese have been damaged, cut and repackaged for display and/or sale, thereby exposing interior surfaces to possible contamination, the cut portions as well as the remaining cheese shall be held under refrigeration.
6. Coffee Creaming Agents - All non-dairy coffee creaming agents in liquid form, except aseptically processed ultra high temperature (UHT) liquid coffee creaming agents.
7. Eggs - Cooked, cracked, fresh with outer shell removed, peeled hard-boiled eggs, and hard-boiled eggs with intact shells which have been hard-boiled and then cooled in liquid. Refrigeration of raw whole eggs in the shell is required.
8. Garlic - Garlic in oil products.
9. Mayonnaise or Other Acidified Salad Dressings - If the pH is above 4.6 and/or combined with other food products.
10. Onions - Cooked and dehydrated that have been reconstituted.
11. Pasta - All types that have been cooked.
12. Pastries - Meat, cheese and cream filled.

13. Pies - Meat, fish, poultry, natural cream, synthetic cream, custard, pumpkin and pies that are covered with toppings which will support microbial growth.
14. Potatoes - Baked, boiled or fried.
15. Rice - Boiled, steamed, fried, Spanish and cooked rice used in sushi.
16. Sauces - Hollandaise and other sauces, containing potentially hazardous ingredients. If these are held in the temperature range of 41°F (5°C) to 140°F (57°C), they must be discarded within four hours of preparation.
17. Sour Cream - If the pH is above 4.6 and/or combined with other food products.
18. Soy Protein - Tofu and other moist soy protein products.
19. Seed Sprouts - All types.

Foods Which Are Not Potentially Hazardous Are:

1. Hard-Boiled eggs with shells intact which have been air-dried;
2. Foods with a water activity ( $a_w$ ) value of 0.85 or less;
3. Foods with a measurement of acidity (pH) of 4.6 or below;
4. Foods which have been adequately commercially processed and remain in their unopened hermetically sealed container; and
5. Food for which laboratory evidence (acceptable to the regulatory authority) demonstrates that rapid progressive growth of infectious and toxigenic microorganisms or the slower growth of C. botulinum cannot occur.

***APPENDIX B - Safe Materials Colorado Pure Food and Drug Law***

**Sections 25-5-402 (3) and (12), C.R.S.**

- (3) a. "Color additive" means a material which:
1. Is a dye, pigment, or other substance made by a process of synthesis or similar artifice or extracted, isolated, or otherwise derived, with or without intermediate or final change of identity, from a vegetable, animal, mineral, or other source; and
  2. When added or applied to a food, drug, or cosmetic or to the human body or any part thereof; is capable (alone or through reaction with other substance) of imparting color thereto; except that such term does not include any material which is exempted under the federal act.
- b. Nothing in this subsection (3) shall be construed to apply to any pesticide chemical, soil or plant nutrient, or other agricultural chemical solely because of its effect in aiding, retarding, or otherwise affecting, directly or indirectly, the growth or other natural physiological process or produce of the soil and thereby affecting its color, whether before or after harvest.
- (12) "Food additive" means any substance, the intended use of which results or may be reasonably expected to result, directly or indirectly, in its becoming a component or otherwise affecting the characteristics of any food (including any substance intended for use in producing, manufacturing, packing, processing, preparing, treating, packaging, transporting, or holding such substance is not generally recognized among experts qualified by scientific training and experience to evaluate its safety as having been adequately shown through scientific procedures or, in the case of a substance used in a food prior to January 1, 1958, through either scientific procedures or experience based on common use in food) to be safe under the conditions of its intended use. The term does not include:
- a. A pesticide chemical in or on a raw agricultural commodity;
  - b. A pesticide chemical to the extent that it is intended for use or is used in the production, storage, or transportation of any raw agricultural commodity;
  - c. A color additive; or
  - d. Any substance used in accordance with a sanction or approval granted prior to the enactment of the amendment to the federal act known as the "Food Additives Amendment of 1958," the Poultry Products Inspection Act" (21 U.S.C. 451-470), or the "Meat Inspection Act of March 4, 1907," as amended and extended (21 U.S.C. 71-91).

***APPENDIX C - Plan Review***

	Date: _____
Name of Establishment: _____	Phone: _____ Fax: _____
Address of Establishment: _____	Phone: _____ Fax: _____
Name of Operator (owner): _____	Phone: _____ FAX: _____
Address of Operator (owner): _____	Phone: _____ FAX: _____
Name of Local Contact: _____	Phone: _____ FAX: _____
Name of Contractor: _____	Phone: _____ FAX: _____
Address of Architect: _____	Phone: _____ FAX: _____
Name of Architect: _____	Phone: _____ FAX: _____

Date Construction will begin: _____	Date of Planned Opening: _____
New Establishment: _____	Remodel: _____

Type of Establishment (check all that apply):

- |  |   |
|--|---|
| <input type="checkbox"/> Full Service                  | <input type="checkbox"/> Coffee Shop      |
| <input type="checkbox"/> Bar                           | <input type="checkbox"/> Market (Grocery) |
| <input type="checkbox"/> Convenience Store             | <input type="checkbox"/> Fish Market      |
| <input type="checkbox"/> Deli                          | <input type="checkbox"/> Meat Market      |
| <input type="checkbox"/> Caterer                       | <input type="checkbox"/> Concession       |
| <input type="checkbox"/> School                        | <input type="checkbox"/> Specialty Shop   |
| <input type="checkbox"/> Fast Food                     | <input type="checkbox"/> Mobile Unit      |
| <input type="checkbox"/> Other (please specify): _____ |   |

Seating Capacity (indoor and outdoor): \_\_\_\_\_

Total Square Feet of the Establishment: \_\_\_\_\_

Total Square Feet of the Kitchen Area: \_\_\_\_\_

Have these plans been submitted or do you intend to submit these plans to other counties in the State of Colorado?  Yes  No If yes, which county(s): \_\_\_\_\_

If Operation is Seasonal, List the Months of Operation: \_\_\_\_\_

---

Day(s) and Hours of Operation: \_\_\_\_\_  
day(s) hours

Projected Daily Maximum Number of Meals to be Served: \_\_\_\_\_ Breakfast  
\_\_\_\_\_ Lunch  
\_\_\_\_\_ Dinner

Number of Staff (maximum per shift): \_\_\_\_\_

**THE FOLLOWING DOCUMENTS ARE NECESSARY AND MUST BE INCLUDED IN ORDER TO COMPLETE THE PLAN REVIEW. LACK OF COMPLETE INFORMATION MAY DELAY REVIEW AND PLAN APPROVAL.**

1. Proposed menu, including a list of foods which will require cooling after cooking and the method that will be used to cool these foods.
2. Facility floor plan. Drawn to scale.
3. Specification sheets of all equipment, including make and model numbers.
4. Shop drawings of all custom fabricated equipment and cabinetry. Drawn to scale.
5. Site plan showing the location of the business in the building, location of the building on site including alleys, streets and the location of any outside facility (dumpsters, walk-in units, grease interceptors etc.).
6. A complete interior finish schedule.
7. Mechanical, plumbing and electrical schedules. Drawn to scale.
8. Water heater specifications, including make and model number.
9. Location of chemical and personal belongings storage.
10. Water supply and wastewater systems.

**I. Menu And Food Handling Procedures:**

- A. Submit Menu
- B. Is there a Hazard Analysis Critical Control Point (HACCP) Plan/Food Handling Procedure Manual that describes preparation, cooling, reheating, cooking of foods and the handling of leftovers? \_\_\_ Yes \_\_\_ No If yes, please submit with plans.
- C. List the foods that will be prepared more than 12 hours in advance of service.
- D. List the foods and describe the methods of how hot foods will be cooled to 41°F (5°C) or below.
- E. List the foods and describe the methods of how foods will be rapidly reheated to 165°F (74°C) or above.
- F. List the foods and indicate how hot foods will be held at 135°F (57°C) or above.
- G. How will frozen foods be thawed?
- H. Will raw meats, poultry, and seafood be stored/displayed in the same refrigerator(s) and freezer(s) with cooked, ready-to-eat foods? \_\_\_ Yes \_\_\_ No
- I. Indicate the total number of refrigeration and freezer units:
- J. Will catering be conducted? \_\_\_ Yes \_\_\_ No
- K. Will food be transported or delivered to another location? \_\_\_ Yes \_\_\_ No  
If yes, what equipment will be provided to maintain food at proper temperatures during transport?
- L. Will the produce used be washed in the establishment, or will all produce be received pre-washed:
- M. Will vacuum packaging be conducted in the establishment? \_\_\_ Yes \_\_\_ No  
If yes, please provide the required HACCP Plan for each category of food to be vacuum packaged.

## **II. Facility Floor Plan:**

- A. Submit Floor Plan Drawn To Scale.
- B. Floor Plan Must Include Location and Identification of All Equipment and Areas Including:
  - 1. Sinks -
    - a) Handsink(s)
    - b) Vegetable/Food Preparation Sink(s)
    - c) Utility/Mop Sink(s)
    - d) Dump Sink(s)
    - e) Warewashing Sink(s)
    - f) Other
  - 2. Wait Station(s)
  - 3. Toilet Facilities
  - 4. Dry/Food Storage Area(s)
  - 5. Employee Break/Locker Area(s)
  - 6. Chemical Storage Area(s)
  - 7. Water Heater Location
  - 8. Bar Service Area(s)
  - 9. Indoor/Outdoor Seating
  - 10. Outdoor Cooking/Bar Area(s)
  - 11. Location Of Laundry Facility
  - 12. Recycle/Damaged/Returned Goods Location
  - 13. Location Of All Floor Sinks and Floor Drains
  - 14. Grease Interceptor/Grease Trap
  - 15. Ice Bins/Ice Machines
  - 16. Dipper Wells
  - 17. Chemical Dispensing Units

### III. Equipment Specifications:

- A. Submit equipment specification sheets, including make and model numbers of the equipment. If the specification sheet lists more than one piece of equipment, identify the specific equipment to be used. If there is no specification sheet available, the equipment will only be accepted upon a field inspection to determine if it meets commercial design criteria.
  
- B. Submit shop drawings of all ventilation hoods. Drawn to scale.
  
- C. Submit shop drawings of all custom fabricated equipment and cabinetry. Drawn to scale.
  
- D. Submit the following water heater information: (See Appendix D for criteria on calculating adequate amounts of hot water)
  - 1. Make: \_\_\_\_\_ Model Number: \_\_\_\_\_
  - 2. BTU/Kilowatt Rating: \_\_\_\_\_
  - 3. Recovery Rate, 100°F rise, at sea level: \_\_\_\_\_



F. Submit the following warewashing information:

1. MANUAL - Include the following for all warewashing sinks: (Kitchen, Dishroom, Bar, etc.)

a) Size of each sink compartment:

Length: \_\_\_\_\_ Width: \_\_\_\_\_ Depth: \_\_\_\_\_

Length: \_\_\_\_\_ Width: \_\_\_\_\_ Depth: \_\_\_\_\_

Length: \_\_\_\_\_ Width: \_\_\_\_\_ Depth: \_\_\_\_\_

b) Size of all soiled and clean drain board(s)/drying racks:

Length: \_\_\_\_\_ Width: \_\_\_\_\_ Depth: \_\_\_\_\_

Length: \_\_\_\_\_ Width: \_\_\_\_\_ Depth: \_\_\_\_\_

Length: \_\_\_\_\_ Width: \_\_\_\_\_ Depth: \_\_\_\_\_

c) Pre-Rinse / Spray Hose Provided: \_\_\_\_\_ yes \_\_\_\_\_ no

2. MECHANICAL:

a) Make and model numbers of warewashing machine(s): \_\_\_\_\_

\_\_\_\_\_

b) Heat or chemical sanitization: \_\_\_\_\_

\_\_\_\_\_

c) Booster Heater:

1. Make and Model Number: \_\_\_\_\_

\_\_\_\_\_

2. Recovery Rate, 40°F Rise, at sea level: \_\_\_\_\_

\_\_\_\_\_

3. Distance from the Warewashing Machine: \_\_\_\_\_

- d) Manufacturer's hot water requirement (gallons per hour): \_\_\_\_\_
- e) Size of all drain boards/drying racks (length and width): \_\_\_\_\_  
\_\_\_\_\_
- f) Pre-Rinse / Spray Hose Provided: \_\_\_\_ Yes \_\_\_\_ No
- g) Soak Sink Provided: \_\_\_\_ Yes \_\_\_\_ No

G. Garbage Disposals: \_\_\_\_ Yes \_\_\_\_ No If yes, Indicate Location(s) \_\_\_\_\_  
\_\_\_\_\_

H. Refrigeration/Freezer Capacities - Complete the following table:

TYPE OF UNIT	# OF UNITS PROVIDED	TOTAL CUBIC FEET
Walk-in Refrigeration		
Reach-in Refrigeration		
Walk-in Freezer		
Reach-in Freezer		
Blast Chiller		
Retail Display		

- I. Displayed Food Items:
  - 1. Bulk Food Items: \_\_\_\_ Yes \_\_\_\_ No If yes, submit equipment specifications for food bins. Include vendor provided equipment.
  - 2. Food Shields - Submit the type and location (If custom design, please submit shop drawings): \_\_\_\_\_

**IV. PREMISES:**

A. Submit site plan which includes the following: Refuse Enclosures, Compactors, Outside Walk-in Cooler(s)/Freezer(s), Location of Water Supply, Sewage Disposal System, Grease Interceptor, Alleys, Streets, Parking and Outside Storage Areas.

B. Water Supply and Wastewater Systems:

1. Water Supply:

a) Community/Public:

Name of District: \_\_\_\_\_

b) Non-Community/Private: \_\_\_\_\_ PWSID #: \_\_\_\_\_

c) Well: \_\_\_\_\_ Spring: \_\_\_\_\_

If it is a well, indicate the depth: \_\_\_\_\_

Method of Disinfection: \_\_\_\_\_

2. Sewage Disposal:

a) Municipal/Public: \_\_\_\_\_

Name of District: \_\_\_\_\_

b) Individual Sewage Disposal System (ISDS): \_\_\_\_\_

**V. Interior Finishes:**

Use the following chart to indicate all interior finishes:

**ROOM FINISH SCHEDULE:**

Room Name and Mark	Floors			Walls (Material and Finish)				Ceilings	
	material	finish	base	North	South	East	West	material	finish
<b>example:</b> Kitchen 101	quarry tile	smooth, sealed	6" quarry tile	FRP smooth	FRP smooth	painted smooth	painted smooth	Vinyl acoustical tile	smooth

**VI. Mechanical, Plumbing, and Electrical Schedules:**

A. Plumbing:

1. Submit the location of all floor sinks and floor drains.
2. List all the equipment that will be installed with an indirect waste pipe.
3. Submit the location of all hose bibbs.
4. Submit the number and location of all toilet fixtures (Including handsinks, urinals, and water closets).
5. Submit the location of the grease trap or interceptor.
6. Submit the make, model and location of all chemical dispensing unit(s).
7. Use the following chart to list the location of all backflow prevention devices, including all vendor supplied items:

<b>EQUIPMENT</b>	<b>INTERNAL PROTECTION</b>	<b>EXTERNAL PROTECTION</b>
Warewashing Machines		
Water Wash Hoods		
Chemical Injection Towers		
Soda Stations		
Coffee Urns		
Ice Makers		
Dipper Wells		
Commercial Disposal with Pre-rinse		
Tea Dispenser		
Mop Sink		
Hose Bibb(s)		
Reel Lines		

<b>EQUIPMENT</b>	<b>INTERNAL PROTECTION</b>	<b>EXTERNAL PROTECTION</b>
Steam Kettle Faucets		

B. Mechanical:

1. Submit a complete ventilation schedule including exhaust capacities (cubic feet per minute ratings) for all hoods and the location and capacity of all make-up air diffusers.
2. If the ventilation hoods are UL listed for lower air flows, submit the information located on the manufacturer's UL listing card.
3. Include ventilation systems in restrooms.

C. Electrical:

1. Submit the location and type of light fixtures throughout the facility, including the fixtures in walk-in refrigeration/freezer units.
2. Submit the type of bulbs and/or shielding for each type of light fixture, where required.
3. Indicate the location of transformers and electrical panels if located in the food preparation/ food storage areas.

## ***APPENDIX D - Worksheet for Calculating Minimum Hot Water Requirements***

The following worksheet is provided to assist operators in calculating hot water usage and sizing of the water heater required for the operation.

### **I. Calculate Total Water Required By All Fixtures:**

#### **A. Three compartment sink calculation of water usage:**

1. Measure dimensions, in inches, of each compartment, if compartments are not the same dimensions see note below.

Length = \_\_\_\_\_ Width = \_\_\_\_\_ Depth = \_\_\_\_\_

2. Insert measurements into equation

$$\left( \frac{\text{Length}}{\text{Length}} \times \frac{\text{Width}}{\text{Width}} \times \frac{\text{Depth}}{\text{Depth}} \times 3 \times .375 \right) \div 231 = \frac{\text{Water Usage}}{\text{Water Usage}}$$

Note: If all the compartment sizes of the sink are not the same, then 3 is taken out of the equation, and the above calculation is done for each compartment. The volumes are added to obtain the total gallons per hour of hot water used in the sink.

Enter number into the attached "Table to Calculate Total Water Required By All Fixtures," found on page Appendix D-4.

#### **B. Utensil soak sink**

1. Measure dimensions, in inches, of the sink

Length = \_\_\_\_\_ Width = \_\_\_\_\_ Depth = \_\_\_\_\_

2. Insert measurements into equation

$$\left( \frac{\text{Length}}{\text{Length}} \times \frac{\text{Width}}{\text{Width}} \times \frac{\text{Depth}}{\text{Depth}} \times .375 \right) \div 231 = \frac{\text{Water Usage}}{\text{Water Usage}}$$

Enter number into the attached "Table to Calculate Total Water Required By All Fixtures," found on page Appendix D-4.

C. Dishmachine and conveyor pre-rinse water usage:

Use manufacturer's rating in gallons per hour

Enter number into attached "Table to Calculate Total Water Required By All Fixtures."

Clothes washer water usage:

Use manufacturer's rating, or 32 GPH for 9-12 pound washer, or 42 GPH for 16 pound washer.

Enter number into the attached "Table to Calculate Total Water Required By All Fixtures," found on page Appendix D-4.

D. Use the gallon per hour rating for each type of fixture found in the "Table to Calculate Total Water Required By All Fixtures" and the number of fixtures in the operation to determine maximum hourly usage for each type of fixture in the operation.

Total water (gph) required by all fixtures: \_\_\_\_\_

II. Calculate Maximum Hourly Hot Water Usage

If gas water heater is used go to Step A; if electric, Step B.

A. Gas Water Heater: If a gas water heater is to be used, calculate the maximum hourly hot water usage for the facility by adjusting the total water required by all fixtures for altitude. The altitude adjustment is 4% per 1000 feet of elevation, or 20% at 5000 feet.

Use the following equations to determine the maximum hourly hot water usage when a gas powered water heater is to be used:

$$(.04 \times \frac{\text{elevation of facility}}{1000}) + 1 = \frac{\text{adjustment factor}}{\text{adjustment factor}}$$

$$\frac{\text{adjustment factor}}{\text{adjustment factor}} \times \frac{\text{total water required by all fixtures}}{\text{total water required by all fixtures}} = \frac{\text{maximum hourly hot water usage}}{\text{maximum hourly hot water usage}}$$

For example, if the total gallon per hour usage for an establishment at an elevation of 5000 feet is 100 GPH, the adjustment factor is 1.2. Therefore, a water heater with 120 GPH recovery rate would be required.

Use this value in the equation to calculate the minimum BTU rating of the water heater.

- B. Electric Water Heater: If an electric water heater is to be used, the maximum hourly usage for the operation is the same as the total water required by all fixtures. Use this value in the equation to calculate the minimum Kilowatt rating of the water heater.
- C. Insert the value determined in step A or B above in III D (3), Appendix C, Plan Review Form, Page Appendix C-6. This value is the minimum recovery rate of the water heater which should be provided for the facility.

III. Calculate the minimum BTU or Kilowatt rating of water heater:

- A. For gas water heater, calculate the minimum BTU rating:

$$\frac{(\text{Max hourly usage as calculated above}) \times (100) \times (8.33)}{.75 \text{ or use manufacturer's thermal efficiency}} = \text{minimum BTU rating}$$

- B. For electric water heater, calculate the minimum Kilowatt rating :

$$\frac{(\text{Max hourly usage as calculated above}) \times (100) \times (8.33)}{3412} = \text{minimum Kilowatt rating}$$

- C. Select water heater based upon BTU or Kilowatt rating.

Make: \_\_\_\_\_ ; Model #: \_\_\_\_\_

BTU or Kilowatt Rating: \_\_\_\_\_

Recovery rate: \_\_\_\_\_ gallons per hour at 100°F rise at sea level.

**Table to Calculate Total Water Required By All Fixtures.**

<b>Plumbing Fixture</b>	<b>Water Usage (gallons per hour)</b>	<b>Number of fixtures</b>	<b>Maximum hourly water usage per type of fixture (gallons per hour)</b>
example: warewashing machine	50	1	50
example: handsink(s)	5	4	(5 x 4 = ) 20
3-compartment sink			
3-compartment sink (bar)			
utensils soak sink			
warewashing machine			
warewashing machine conveyor pre-rinse			
clothes washer			
hand operated pre-rinse sprayer	32		
handsink(s), include rest rooms	5		
mop sink	7		
garbage can washer	35		
showers	14		
hose bibb used for cleaning	35		
<b>Total water (gph) required by all fixtures</b>			

## *APPENDIX E – Specific Usage Additives*

### **173.310 Boiler water additives.**

Boiler water additives may be safely used in the preparation of steam that will contact food, under the following conditions:

- A. The amount of additive is not in excess of that required for its functional purpose, and the amount of steam in contact with food does not exceed that required to produce the intended effect in or on the food.
- B. The compounds are prepared from substances identified in paragraphs (c) and (d) of this section, and are subject to the limitations, if any, prescribed:

C. List of substances:

Substances	Limitations
Acrylamide-sodium acrylate resin .....	Contains not more than 0.05 percent by weight of acrylamide monomer.
Acrylic acid/2-acrylamido-2-methyl propane sulfonic acid copolymer having a minimum weight average molecular weight of 9,900 and a minimum number average molecular weight of 5,700 as determined by a method entitled "Determination of Weight Average and Number Average Molecular Weight of 60/40 AA/AMPS" (October 23, 1987), which is incorporated by reference in accordance with 5 U.S.C. 552(a). Copies may be obtained from the Center for Food Safety and Applied Nutrition (HFS-200), Food and Drug Administration, 200 C St. SW., Washington, DC 20204, or may be examined at the Office of the Federal Register, 800 North Capitol Street, NW., suite 700, Washington, DC.	Total not to exceed 20 parts per million (active) in boiler feedwater.
Ammonium alginate.	
Cobalt sulfate (as catalyst).	
1-hydroxyethylidene-1, 1-diphosphonic acid (CAS Reg. No. 2809-21-4) and its sodium and potassium salts.	
Lignosulfonic acid.	
Monobutyl ethers of polyethylene-polypropylene glycol produced by random condensation of a 1:1 mixture by weight of ethylene oxide and propylene oxide with butanol.	Minimum mol. Wt. 1,500.
Poly(acrylic acid-co-hypophosphite), sodium salt (CAS Reg. No. 71050-62-9), produced from a 4:1 to a 16:1 mixture by weight of acrylic acid and sodium hypophosphite.	Total not to exceed 1.5 parts per million in boiler feed water. Copolymer contains not more than 0.5 percent by weight of acrylic acid monomer (dry weight basis).
Polyethylene glycol.....	As defined in 172.820 of this chapter.
Polymaleic acid [CAS Reg. No. 26099-09-2], and/or its sodium salt. [..CAS Reg. No. 30915-61-8 or CAS Reg. No. 70247-90-4].	Total not to exceed 1 part per million in boiler feed water (calculated as the acid).





D. Substances used alone or in combination with substances in paragraph (c) of this section:

Substances	Limitations
Cyclohexylamine .....	Not to exceed 10 parts per million in steam, and excluding use of such steam in contact with milk and milk products.
Diethylaminoethanol .....	Not to exceed 15 parts per million in steam, and excluding use of such steam in contact with milk and milk products.
Hydrazine .....	Zero in steam.
Morpholine .....	Not to exceed 10 parts per million in steam, and excluding use of such steam in contact with milk and milk products.
Octadecylamine .....	Not to exceed 3 parts per million in steam, and excluding use of such steam in contact with milk and milk products
Trisodium nitrilotriacetate .....	Not to exceed 5 parts per million in boiler feedwater; not to be used where steam will be in contact with milk and milk products.

E. To assure safe use of the additive, in addition to the other information required by the Act, the label or labeling shall bear:

1. The common or chemical name or names of the additive or additives.
2. Adequate directions for use to assure compliance with all the provisions of this section.

**APPENDIX F - Lubricants**

178.3570 Lubricants With Incidental Food Contact

Lubricants with incidental food contact may be safely used on machinery used for producing, manufacturing, packing, processing, preparing, treating, packaging, transporting, or holding food, subject to the provisions of this section.

- A. The lubricants are prepared from one or more of the following substances.
1. Substances generally recognized as safe for use in food.
  2. Substances used in accordance with the provisions of a prior sanction or approval.
  3. Substances identified in this paragraph (a)(3).

Substances	Limitations
Aluminum stearoyl benzoyl hydroxide .....	For use only as a thickening agent in mineral oil lubricants at a level not to exceed 10 pct by weight of the mineral oil.
BHA.	
BHT.	
γ-Butyl-omega-hydroxypoly(oxyethylene) poly(oxypropylene) produced by random condensation of a 1:1 mixture by weight of ethylene oxide and propylene oxide with butanol; minimum molecular weight 1,500; Chemical Abstracts Service Registry No. 9038-95-3.	Addition to food not to exceed 10 parts per million.
γ-Butyl-omega-hydroxypoly(oxypropylene); minimum molecular weight 1,500; Chemical Abstracts Service Registry No. 9003-13-8.	Do.
Castor oil .....	Do.
Castor oil, dehydrated .....	Do.
Castor oil, partially dehydrated .....	Do.

Substances	Limitations
<p>Dialkyldimethylammonium aluminum silicate (CAS Reg. No. 68953-58-2), which may contain up to 7 percent by weight 1,6-hexanediol (CAS Reg. No. 629-11-8), where the alkyl groups are derived from hydrogenated tallow fatty acids (C<sub>14</sub>-C<sub>18</sub>) and where the aluminum silicate is derived from bentonite.</p>	<p>For use only as a wetting agent in mineral oil lubricants at a level not to exceed 15 percent by weight of the mineral oil.</p>
<p>Dimethylpolysiloxane (viscosity greater than 300 centistokes).</p>	<p>Addition to food not to exceed 1 part per million.</p>
<p>Disodium decanedioate (CAS Reg. No. 17265-14-4).</p> <p>Disodium EDTA (CAS Reg. No. 139-33-3) .....</p> <p>Ethoxylated resin phosphate ester mixture consisting of the following compounds:</p> <ol style="list-style-type: none"> <li>1. Poly(methylene-p-tert-butyl-phenoxy) poly(oxyethylene) mixture of dihydrogen phosphate and monohydrogen phosphate esters (0-40 percent of the mixture). The resin is formed by condensation of 1 mole of p-tert-butylphenol with 2 to 4 moles of formaldehyde and subsequent ethoxylation with 4 to 12 moles of ethylene oxide;</li> <li>2. Poly(methylene-p-nonylphenoxy) poly(oxyethylene) mixture of dihydrogen phosphate and monohydrogen phosphate esters (0-40 percent of the mixture). The resin is formed by condensation of 1 mole of p-nonylphenol with 2 to 4 moles of formaldehyde and subsequent ethoxylation with 4 to 12 moles of ethylene oxide; and</li> <li>3. N-Tridecyl alcohol mixture of dihydrogen phosphate and monohydrogen phosphate esters (40 to 80 percent of the mixture; CAS Reg. No. 56831-62-0).</li> </ol> <p>Fatty acids derived from animal or vegetable sources, and the hydrogenated forms of such fatty acids.</p> <p>2-(8-Heptadecenyl)-4,5-dihydro-1 H-imidazole-1-ethanol(CAS Reg. No. 95-38-5).</p>	<p>For use as a corrosion inhibitor or rust preventative in mineral oil-bentonite lubricants at a level not to exceed 2 percent by weight of the grease.</p> <p>For use only as a chelating agent and sequestrant at a level not to exceed 0.06 percent by weight of lubricant at final use dilution.</p> <p>For use only as a surfactant to improve lubricity in lubricating fluids complying with this section at a level not to exceed 5 percent by weight of the lubricating fluid.</p> <p>For use at levels not to exceed 0.5 percent by weight of the lubricant.</p>

Substances	Limitations
<p>Hexamethylenebis(3,5-di-tert-butyl-4-hydroxyhydrocinnamate) (CAS Reg. No. 35074-77-2).</p> <p><math>\alpha</math>-Hydro-omega-hydroxypoly (oxyethylene) poly(oxypropylene) produced by random condensation of mixtures of ethylene oxide and propylene oxide containing 25 to 75 percent by weight of ethylene oxide; minimum molecular weight 1,500; Chemical Abstracts Service Registry No. 9003-11-6.</p> <p>12-Hydroxystearic acid.</p>	<p>For use as an antioxidant at levels not to exceed 0.5 percent by weight of the lubricant.</p> <p>Addition to food not to exceed 10 parts per million.</p>
<p>Isopropyl oleate .....</p>	<p>For use only as an adjuvant (to improve lubricity) in mineral oil lubricants.</p>
<p>Magnesium ricinoleate .....</p> <p>Mineral oil .....</p> <p>N-Methyl-N-(1-oxo-9-octadecenyl)glycine (CAS Reg. No. 110-25-8).</p> <p>N-phenylbenzenamine, reaction products with 2,4,4-trimethylpentene (CAS Reg. No. 68411-46-1).</p> <p>Petrolatum .....</p> <p>Phenyl-<math>\gamma</math>-and/or phenyl-<math>\beta</math>-naphthylamine .....</p> <p>Phosphoric acid, mono- and dihexyl esters, compounds with tetramethylnonylamines and C<sub>11-14</sub> alkylamines.</p> <p>Phosphoric acid, mono- and diisooctyl esters, reacted with tertalkyl and (C<sub>12</sub>-C<sub>14</sub>) primary amines (CAS Reg. No. 68187-67-7).</p> <p>Polyurea, having a nitrogen content of 9-14 percent based on the dry polyurea weight, produced by reacting tolylene diisocyanate with tall oil fatty acid (C<sub>16</sub> and C<sub>18</sub>) amine and ethylene diamine in a 2:2:1 molar ratio.</p> <p>Polybutene (minimum average molecular weight 80,000)</p>	<p>For use only as an adjuvant in mineral oil lubricants at a level not to exceed 10 percent by weight of the mineral oil.</p> <p>Addition to food not to exceed 10 parts per million.</p> <p>For use as a corrosion inhibitor at levels not to exceed 0.5 percent by weight of the lubricant.</p> <p>For use only as an antioxidant at levels not to exceed 0.5 percent by weight of the lubricant.</p> <p>Complying with 178.3700. Addition to food not to exceed 10 parts per million.</p> <p>For use only, singly or in combination, as antioxidant in mineral oil lubricants at a level not to exceed a total of 1 percent by weight of the mineral oil.</p> <p>For use only as an adjuvant at levels not to exceed 0.5 percent by weight of the lubricant.</p> <p>For use only as a corrosion inhibitor or rust preventative in lubricants at a level not to exceed 0.5 percent by weight of the lubricant.</p> <p>For use only as an adjuvant in mineral oil lubricants at a level not to exceed 10 percent by weight of the mineral oil.</p> <p>Addition to food not to exceed 10 parts per million</p>

Substances	Limitations
Polybutene, hydrogenated; complying with the identity prescribed under 178.3740. Polyethylene ..... Polyisobutylene (average molecular weight 35,000-140,000 (Flory)). Sodium nitrite .....  Tetrakis{methylene(3,5-di-tert-butyl-4-hydroxyhydro-cinnamate)}methane (CAS Reg. No. 6683-19-8). Thiodiethylenebis (3,5-di-tert-butyl-4-hydroxyhydrocinnamate) (CAS Reg. No. 41484-35-9).	Do.  Do. For use only as a thickening agent in mineral oil lubricants. For use only as a rust preventive in mineral oil lubricants at a level not to exceed 3 percent by weight of the mineral oil. For use only as an antioxidant at levels not to exceed 0.5 percent by weight of the lubricant. For use as an antioxidant at levels not to exceed 0.5 percent by weight of the lubricant.
Triphenyl phosphorothionate (CAS Reg. No. 597-82-0)	For use as an adjuvant in lubricants herein listed at a level not to exceed 0.5 percent by weight of the lubricant.
Tris(2,4-di-tert-butylphenyl)phosphite (CAS Reg No. 31570-04-4). Thiodiethylenebis(3,5-di-tert-butyl-4-hydroxyhydro-cinnamate)(CAS Reg. No. 41484-35-9). Zinc sulfide .....	For use only as a stabilizer at levels not to exceed 0.5 percent by weight of the lubricant. For use as an antioxidant at levels not to exceed 0.5 percent by weight of the lubricant. For use at levels not to exceed 10 percent by weight of the lubricant.

- B. The lubricants are used on food processing equipment as a protective antirust film, as a release agent on gaskets or seals of tank closures, and as a lubricant for machine parts and equipment in locations in which there is exposure of the lubricated part to food. The amount used is the minimum required to accomplish the desired technical effect on the equipment, and the addition to food of any constituent identified in this section does not exceed the limitations prescribed.
- C. Any substance employed in the production of the lubricants described in this section that is the subject of a regulation in parts 174, 175, 176, 177, 178 and 179.45 of this chapter conforms with any specification in such regulation.

***APPENDIX G - SANITIZERS***

***Refer to 21 CFR § 178.101, (2003) Sanitizing solutions***

## ***APPENDIX H - HACCP Guidelines***

- 1) Introduction**
- 2) HACCP Principles**
- 3) Summary**
- 4) Acknowledgments**
- 5) Bibliography**
- 6) Other Sources of HACCP Information**

### **1) Introduction**

The acronym HACCP stands for Hazard Analysis and Critical Control Point, which is a prevention-based food safety system. HACCP systems are designed to prevent the occurrence of potential food safety problems. This is achieved by assessing the inherent risks attributable to a product of a process and then determining the necessary steps that will control the identified risks.

Essentially, HACCP is a system that identifies and monitors specific foodborne hazards--biological, chemical, or physical properties--that can adversely affect the safety of the food product. This hazard analysis serves as the basis for establishing critical control points (CCPs). CCPs identify those points in the process that must be controlled to assure the safety of the food. Further, critical limits are established that document the appropriate parameters that must be met at each CCP. Monitoring and verification steps are included in the system, again, to assure that potential risks are controlled. The hazard analysis, critical control points, critical limits, and monitoring and verification steps are documented in a HACCP plan. Seven principles have been developed which provide guidance on the development of an effective HACCP plan.

HACCP represents an important food protection tool. HACCP is not something limited to food franchises or chains. The concept can be applied by small independents as well as national or regional companies and can be integrated into the recipes and standard operating procedures of any size establishment. Employee training is key to successful implementation. Employees must learn which control points are critical in an operation and what the critical limits are at these points, for each preparation step they perform.

Establishment management must also follow through by routinely monitoring the food operation to verify that employees are keeping the process under control by complying with the critical limits.

As is the case with industry, mastering and applying regulatory aspects of HACCP is not limited to large state programs. Local jurisdictions can effectively promote HACCP and apply the concept during inspections. The implementation of HACCP continues to evolve and to be further refined as new products and procedures are developed and as hazards and their control measures are more clearly defined. To meet the challenges presented by advances in food

research, product development, and their impact at retail, regulatory personnel must keep themselves informed. Food protection publications issued by the food industry, professional organizations, and other groups and continuing education programs can be particularly helpful in providing an understanding of food operations and how the application of HACCP can bring a focus to food safety that traditional inspection methods have lacked.

#### A) Definitions

Many terms are used in discussion of HACCP that must be clearly understood to effectively develop and implement a plan. The following definitions are provided for clarity:

- 1) **Acceptable level** means the presence of a hazard which does not pose the likelihood of causing an unacceptable health risk.
- 2) **Control point** means any point in a specific food system at which loss of control does not lead to an unacceptable health risk.
- 3) **Critical control point**, as defined in the Food Code, means a point at which loss of control may result in an unacceptable health risk.
- 4) **Critical limit**, as defined in the Food Code, means the maximum or minimum value to which a physical, biological, or chemical parameter must be controlled at a critical control point to minimize the risk that the identified food safety hazard may occur.
- 5) **Deviation** means failure to meet a required critical limit for a critical control point.
- 6) **HACCP plan**, as defined in the Food Code, means a written document that delineates the formal procedures for following the HACCP principles developed by The National Advisory Committee on Microbiological Criteria for Foods.
- 7) **Hazard**, as defined in the Food Code, means a biological, chemical, or physical property that may cause an unacceptable consumer health risk.
- 8) **Monitoring** means a planned sequence of observations or measurements of critical limits designed to produce an accurate record and intended to ensure that the critical limit maintains product safety. Continuous monitoring means an uninterrupted record of data.
- 9) **Preventive measure** means an action to exclude, destroy, eliminate, or reduce a hazard and prevent recontamination through effective means.
- 10) **Risk** means an estimate of the likely occurrence of a hazard.
- 11) **Sensitive ingredient** means any ingredient historically associated with a known microbiological hazard that causes or contributes to production of a potentially hazardous food as defined in the Food Code.
- 12) **Verification** means methods, procedures, and tests used to determine if the HACCP system in use is in compliance with the HACCP plan.

#### B) History

The application of HACCP to food production was pioneered by the Pillsbury Company with the cooperation and participation of the National Aeronautic and Space Administration (NASA), Natick Laboratories of the U.S. Army, and the U.S. Air Force Space Laboratory Project Group. Application of the system in the early 1960s created food for the United State's space program that approached 100% assurance against contamination by bacterial and viral pathogen, toxins, and chemical or physical hazards that could cause illness or injury to astronauts. HACCP replaced end-product testing to provide food safety assurance and provided a preventive system for producing safe food that had universal application.

In the succeeding years, the HACCP system has been recognized worldwide as an effective system of controls. The system has undergone considerable analysis, refinement, and testing and is widely accepted in the United States and internationally.

### C) Advantages of HACCP

FDA is recommending the implementation of HACCP in food establishments because it is a system of preventive controls that is the most effective and efficient way to assure that food products are safe. A HACCP system will emphasize the industry's role in continuous problem solving and prevention rather than relying solely on periodic facility inspections by regulatory agencies.

HACCP offers two additional benefits over conventional inspection techniques. First, it clearly identifies the food establishment as the final party responsible for assuring the safety of the food it produces. HACCP requires the food establishment to analyze its preparation methods in a rational, scientific manner in order to identify critical control points and to establish critical limits and monitoring procedures. A vital aspect of the establishment's responsibility is to establish and maintain records that document adherence to the critical limits that relate to the identified critical control points, thus resulting in continuous self-inspection. Secondly, a HACCP system allows the regulatory agency to more comprehensively determine an establishment's level of compliance. A food establishment's use of HACCP requires development of a plan to prepare safe food. This plan must be shared with the regulatory agency because it must have access to CCP monitoring records and other data necessary to verify that the HACCP plan is working. Using conventional inspection techniques, an agency can only determine conditions during the time of inspection which provide a "snapshot" of conditions at the moment of the inspection. However, by adopting a HACCP approach, both current and past conditions can be determined. When regulatory agencies review HACCP records, they have, in effect, a look back through time. Therefore, the regulatory agency can better assure that processes are under control.

Traditional inspection is relatively resource-intensive and inefficient and is reactive rather than preventive compared to the HACCP approach for assuring food safety. Regulatory agencies are challenged to find new approaches to food safety that enable them to become more focused and efficient and to minimize costs wherever possible. Thus, the advantages of HACCP-based inspections are becoming increasingly acknowledged by the regulatory community.

Examples of the successful implementation of HACCP by food establishments may be found throughout the food industry. During the past several years, FDA and a number of state and local jurisdictions have worked with two national voluntary pilot projects for retail food stores and restaurants. These projects involved more than 20 food establishments and demonstrated that HACCP concepts have matured to the point at which they can be formally implemented for all food products on an industry-wide basis.

## **2. HACCP Principles**

### **A) Background**

The National Advisory Committee on Microbiological Criteria for Foods (NACMCF), which developed HACCP principles, was established in 1988 and has as members, officials from several federal agencies which include the Food and Drug Administration, the Centers for Disease Control and Prevention, the Food Safety Inspection Service, the Agricultural Research Service, the National Marine Fisheries Service, and the U.S. Army. The NACMCF also has national experts from academia, state government, consumer groups, and the food industry.

### **B) Principles**

The NACMCF has developed seven widely accepted HACCP principles that explain this process in great detail. To prepare an effective HACCP plan these principles must be followed. Further, a comprehensive review of a HACCP plan must include consideration of these principles. These HACCP principles are discussed below.

## 1) **Principle #1: Hazard Analysis**

### a) Purposes

The hazard analysis process accomplishes three purposes:

- i) Hazards of significance are identified;
- ii) The hazard analysis provides a risk basis for selecting likely hazards;
- iii) Identified hazards can be used to develop preventive measures for a process or product to assure or improve food safety.

Before beginning to develop a HACCP plan, a team should be assembled that is familiar with the overall food operation and the specific production processes to be included in the plan. The team's goal and each member's responsibilities in reaching the goal must be clearly defined.

The first step in the development of a HACCP plan for a food operation is identification of hazards associated with the product. A hazard may be a biological, chemical, or physical property that can cause a food to be unsafe.

Hazard analysis should include risk assessment of both the likelihood that these hazards will occur and their severity if they do occur. Hazard analysis also involves establishment of preventive measures for control. Hazards that involved low risk and that are not likely to occur need not be considered for the purposes of HACCP.

To be effectively addressed, hazards must be such that their prevention, elimination, or reduction to acceptable levels is attained.

Numerous issues have to be considered during hazard analysis. These relate to factors such as ingredients, processing, distribution, and the intended use of the product. These issues include whether a food contains sensitive ingredients that can create microbiological, chemical, or physical hazards; or whether sanitation practices that are used can introduce these hazards to the food that is being prepared or processed. An example is whether the finished food will be heated by the consumer, if it is consumed off the premises. Even factors beyond the immediate control of the food establishment, such as how the food will be treated if taken out by the consumer and how it will be consumed, must be considered because these factors could influence how food should be prepared or processed in the establishment.

### b) Flow Diagram

Consequently, a flow diagram that delineates the steps in the process from receipt to sale or service forms the foundation for applying the seven principles. The significant hazards associated with each step in the flow diagram should be listed along with preventive measures proposed to control the hazards. This tabulation will be used under Principle 2 to determine the CCPs. The flow diagram should be constructed by a HACCP team that has knowledge and expertise on the

product, process, and the likely hazards. Each step in a process should be identified and observed to accurately construct the flow diagram. Some examples of flow diagrams are found at the end of this Appendix.

c) Biological Hazards

Foodborne biological hazards include bacterial, viral, and parasitic organisms. These organisms are commonly associated with humans and with raw products entering the food establishment.

Many of these pathogens occur naturally in the environment where foods are grown. Most are killed or inactivated by adequate cooking and numbers are kept to a minimum by adequate cooling during distribution and storage.

Bacterial pathogens comprise the majority of reported foodborne disease outbreaks and cases. A certain level of the pathogens can be expected with some raw foods. Temperature abuse, such as improper hot or cold holding temperatures, can significantly magnify this number. Cooked food which has been subject to cross-contamination with pathogens often provides a fertile medium for their rapid and progressive growth.

Enteric viruses can be foodborne, waterborne, or transmitted from a person or from animals. Unlike bacteria, a virus cannot multiply outside of a living cell. Hepatitis A and Noroviruses are examples of viral hazards associated with ready-to-eat foods.

Parasites are most often animal host-specific and can include humans in their life cycles. Parasitic infections are commonly associated with undercooking meat products or cross contamination of ready-to-eat food. Fishborne parasites in products that are intended to be eaten raw, marinated, or partially cooked can be killed by effective freezing techniques.

The following table provides an assessment of severity of the biological hazards which may be associated with food being prepared, served, or sold in food establishments.

**Table 1. Hazardous Microorganisms and Parasites Grouped on the Basis of Risk Severity<sup>a</sup>**

**Severe Hazards**

*Clostridium botulinum* types A, B, E, and F  
*Shigella dysenteriae*  
*Salmonella typhi*; *paratyphi* A, B  
*Hepatitis A* and E  
*Brucella abortis*; *B. suis*  
*Vibrio cholerae* 01  
*Vibrio vulnificus*  
*Taenia solium*  
*Trichinella spiralis*

**Moderate Hazards: Potentially Extensive Spread<sup>b</sup>**

*Listeria monocytogenes*  
*Salmonella* spp.  
*Enterovirulent Escherichia coli* (EEC)  
*Streptococcus pyogenes*  
Rotavirus  
Norovirus group  
*Entamoeba histolytica*  
*Diphyllobothrium latum*  
*Ascaris lumbricoides*  
*Cryptosporidium parvum*

**Moderate Hazards: Limited Spread**

*Bacillus cereus*  
*Campylobacter jejuni*  
*Clostridium perfringens*  
*Staphylococcus aureus*  
*Vibrio cholerae*, non-01  
*Vibrio parahaemolyticus*  
*Yersinia enterocolitica*  
*Giardia lamblia*  
*Taenia saginata*

---

<sup>a</sup>Adapted from International Commission on Microbiological Specifications for Food (ICMSF) (1986). Used with permission, "HACCP Principles and Applications," Pierson and Corlett, Eds. 1992. Chapman & Hall, New York, NY.

<sup>b</sup>Although classified as moderate hazards, complications and sequelae may be severe in certain susceptible populations.

d) Chemical Hazards

Chemical hazards in foods should be considered during a hazard analysis. Chemical contaminants may be naturally occurring or may be added during the processing of food. Harmful chemicals at very high levels have been associated with acute cases of foodborne illnesses and can be responsible for chronic illness at lower levels.

The following table provides some examples of chemical hazards found within the naturally occurring and added chemical categories. The Code of Federal Regulations, Title 21, provides guidance on naturally occurring toxic substances and allowable limits for many of the chemicals added during processing (food additives). The FDA Compliance Policy Guidelines also provide information on other naturally occurring chemicals.

**Table 2. Types of Chemical Hazards and Examples<sup>a</sup>**

**Naturally Occurring Chemicals**

Mycotoxins (e.g., aflatoxin) from mold  
Scombrototoxin (histamine) from protein decomposition  
Ciguatoxin from marine dinoflagellates  
Toxic mushroom species  
Shellfish toxins (from marine dinoflagellates)  
    Paralytic shellfish poisoning (P.P.)  
    Diarrhetic shellfish poisoning (DSP)  
    Neurotoxic shellfish poisoning (NSP)  
    Amnesic shellfish poisoning (ASP)  
Plant toxins  
Pyrrolizidine alkaloids  
Phytohemagglutinin

**Added Chemicals**

Agricultural chemicals: Pesticides, fungicides, fertilizers, insecticides, antibiotics and growth hormones

Polychlorinated biphenyls (PCBs)

Industrial chemicals

Prohibited substances (21 CFR §189)

    Direct

    Indirect

Toxic elements and compounds: Lead, zinc, arsenic, mercury, and cyanide

Food additives:

    Direct: allowable limits under GMPs

        Preservatives (nitrite and sulfiting agents)

        Flavor enhancers (monosodium glutamate)

        Nutritional additives (niacin)

        Color additives

    Secondary direct and indirect

        Chemicals used in establishments (e.g., lubricants, cleaners, sanitizers, cleaning compounds, coatings, and paints)

Poisonous or toxic chemicals intentionally added (sabotage)

<sup>a</sup>Used with permission, "HACCP Principles and Applications," Pierson and Corlett, Eds. 1992. Chapman & Hall, New York, NY and adapted.

e) Physical Hazards

Illness and injury can result from hard foreign objects in food. These physical hazards can result from contamination and/or poor procedures at many points in the food chain from harvest to consumer, including those within the food establishment.

As establishments develop their HACCP programs, the following table can be used to further identify sources of potential physical risks to the food being prepared, served, or sold.

**Table 3. Main Materials of Concern as Physical Hazards and Common Sources<sup>a,b</sup>**

<b>Material</b>	<b>Injury Potential</b>	<b>Sources</b>
Glass fixtures	Cuts, bleeding; may require surgery to find or remove	Bottles, jars, light, utensils, gauge covers
Wood	Cuts, infection, choking; may require surgery to remove	Fields, pallets, boxes, buildings
Stones, metal fragments	Choking, broken teeth Cuts, infection; may require surgery to remove	Fields, buildings, machinery, wire, employees
Insulation	Choking; long-term if asbestos	Building materials
Bone	Choking, trauma	Fields, improper plant processing
Plastic	Choking, cuts, infection; may require surgery to remove	Fields, plant packaging materials, pallets, employees
Personal effects	Choking, cuts, broken teeth; may require surgery to remove	Employees

<sup>a</sup>Adapted from Corlett (1991).

<sup>b</sup>Used with permission, "HACCP Principles and Applications," Pierson and Corlett, Eds. 1992. Chapman & Hall, New York, NY.

f) Determining Level of Risk

The potential significance or risk of each hazard should be assessed by considering its likelihood of occurrence and severity. The estimate of risk for a hazard occurring is based upon a combination of experience, epidemiological data, and information in the technical literature. Severity is the degree of seriousness of the consequences of a hazard if it were to become an actuality.

Hazard identification in conjunction with risk estimation provides a rational basis for determining which hazards are significant and must be addressed in the HACCP plan. To determine risk during the hazard analysis, safety concerns must be differentiated from quality concerns. A food safety hazard is a biological, chemical, or physical property that may cause a food to be unsafe. There may be differences of opinion, even among experts, as to the risk of a hazard. The food establishment must rely upon the expert opinion published in peer reviewed literature or experts who actively assist in the development of the HACCP plan. The hazards must at least include those that are commonly associated with a specific product. If a hazard that is commonly associated is dismissed from the plan, the basis for rejecting it must be clearly stated in the hazard analysis so that it is understood and agreed to by the regulatory authority reviewing the HACCP plan.

g) Hazard Analysis Process

This point in hazard analysis consists of asking a series of questions which are appropriate to each step in the flow diagram. The hazard analysis should question the effect of a variety of factors upon the safety of the food.

i) Ingredients

- Does the food contain any sensitive ingredients that are likely to present microbiological hazards (e.g., Salmonella, Staphylococcus aureus), chemical hazards (e.g., aflatoxin, antibiotic, or pesticide residues) or physical hazards (stones, glass, bone, metal)?

ii) Intrinsic Factors of Food

- Physical characteristics and composition (e.g., pH, type of acids, fermentable carbohydrate, water activity, preservatives) of the food during and after preparation can cause or prevent a hazard.
- Which intrinsic factors of the food must be controlled in order to assure food safety?
- Does the food permit survival or multiplication of pathogens and/or toxin formation in the food before or during preparation?

- Will the food permit survival or multiplication of pathogens and/or toxin formation during subsequent steps of preparation, storage, or consumer possession?
- Are there other similar products in the market place? What has been the safety record for these products?

- iii) Procedures Used for Preparation/ Processing
  - Does the preparation procedure or process include a controllable step that destroys pathogens or their toxins? Consider both vegetative cells and spores.
  - Is the product subject to recontamination between the preparation step (e.g., cooking) and packaging?
- iv) Microbial Content of the Food
  - Is the food commercially sterile (i.e., low acid canned food)?
  - Is it likely that the food will contain viable sporeforming or nonsporeforming pathogens?
  - What is the normal microbial content of the food stored under proper conditions?
  - Does the microbial population change during the time the food is stored before consumption?
  - Does that change in microbial population alter the safety of the food?
- v) Facility Design
  - Does the layout of the facility provide an adequate separation of raw materials from ready-to-eat foods?
  - Is positive air pressure maintained in product packaging areas? Is this essential for product safety?
  - Is the traffic pattern for people and moving equipment a potentially significant source of contamination?
- vi) Equipment Design
  - Will the equipment provide the time/temperature control that is necessary for safe food?
  - Is the equipment properly sized for the volume of food that will be prepared?
  - Can the equipment be sufficiently controlled so that the variation in performance will be within the tolerance required to produce a safe food?
  - Is the equipment reliable or is it prone to frequent breakdowns?
  - Is the equipment designed so that it can be cleaned and sanitized?
  - Is there a chance for product contamination with hazardous substances, e.g., glass?

- What product safety devices such as time/temperature integrators are used to enhance consumer safety?

- vii) Packaging
  - Does the method of packaging affect the multiplication of microbial pathogens and/or the formation of toxins?
  - Is the packaging material resistant to damage, thereby preventing the entrance of microbial contamination?
  - Is the package clearly labeled “Keep Refrigerated” if this is required for safety?
  - Does the package include instructions for the safe handling and preparation of the food by the consumer?
  - Are tamper-evident packaging features used?
  - Is each package legibly and accurately coded to indicate production lot?
  - Does each package contain the proper label?
- viii) Sanitation
  - Can the sanitation practices that are employed impact upon the safety of the food that is being prepared?
  - Can the facility be cleaned and sanitized to permit the safe handling of food?
  - Is it possible to provide sanitary conditions consistently and adequately to assure safe foods?
- ix) Employee health, hygiene, and education
  - Can employee health or personal hygiene practices impact the safety of the food being prepared?
  - Do the employees understand the food preparation process and the factors they must control to assure safe foods?
  - Will the employees inform management of a problem which could impact food safety?
- x) Conditions of storage between packaging and the consumer
  - What is the likelihood that the food will be improperly stored at the wrong temperature?
  - Would storage at improper temperatures lead to a microbiologically unsafe food?
- xi) Intended use
  - Will the food be heated by the consumer?
  - Will there likely be leftovers?

xii) Intended consumer

- Is the food intended for the general public, i.e., a population that does not have an increased risk of becoming ill.
- Is the food intended for consumption by a population with increased susceptibility to illness (e.g., infants, the elderly, the infirm, and immunocompromised individuals)?

h) Developing Preventive Measures

The preventive measures procedure identifies the steps in the process at which hazards can be controlled.

After identifying the hazards the food establishment must then consider what preventive measures, if any, can be applied for each hazard. Preventive measures are physical, chemical, or other factors that can be used to control an identified health hazard. More than one preventive measure may be required to control a specific hazard and more than one hazard may be controlled by a specified preventive measure.

For example, if a HACCP team were to conduct a hazard analysis for the preparation of hamburgers from frozen beef patties, enteric pathogens on the incoming raw meat would be identified as a potential hazard. Cooking is a preventive measure which can be used to eliminate this hazard. Thus, cooking, the preventive measure, would be listed along with the hazard (i.e., enteric pathogens) as follows:

Step	Identified Hazard	Preventive Measures
Cooking	Enteric pathogens	Cooking sufficiently to kill enteric pathogens

**2) Principle #2: Identify the Critical Control Points (CCP) in Food Preparation**

A CCP is a point, step, or procedure at which control can be applied and a food safety hazard can be prevented, eliminated, or reduced to acceptable levels. Points in food preparation that may be CCPs include cooking, chilling, specific sanitation procedures, product formulation control, prevention of cross contamination, and certain aspects of employee and environmental hygiene. For example, cooking that must occur at a specific temperature and for a specified time in order to destroy microbiological pathogens is a critical control point. Likewise, refrigeration or the adjustment of a food's pH to a level required to prevent hazardous microorganisms from multiplying or toxins from forming are also CCPs.

Many points in food preparation may be considered control points, but very few are actually critical control points. A control point is any point, step, or procedure at which biological, physical, or chemical factors can be controlled. Concerns that do not impact food safety may be addressed at control points; however, since these control points do not relate to food safety, they are not included in the HACCP plan.

Different facilities preparing the same food can differ in the risk of hazards and the points, steps, or procedures which are CCPs. This can be due to differences in each facility such as layout, equipment, selection of ingredients, or the process that is used. Generic HACCP plans can serve as useful guides; however, it is essential that the unique conditions within each facility be considered during the development of a HACCP plan.

CCPs must be carefully developed and documented. In addition, they must be used only for purposes of product safety. The following decision tree is helpful in verifying which of the food preparation steps should be designated as CCPs.



### Critical Control Point Decision Tree

(Apply at each step in food preparation that has an identified hazard)

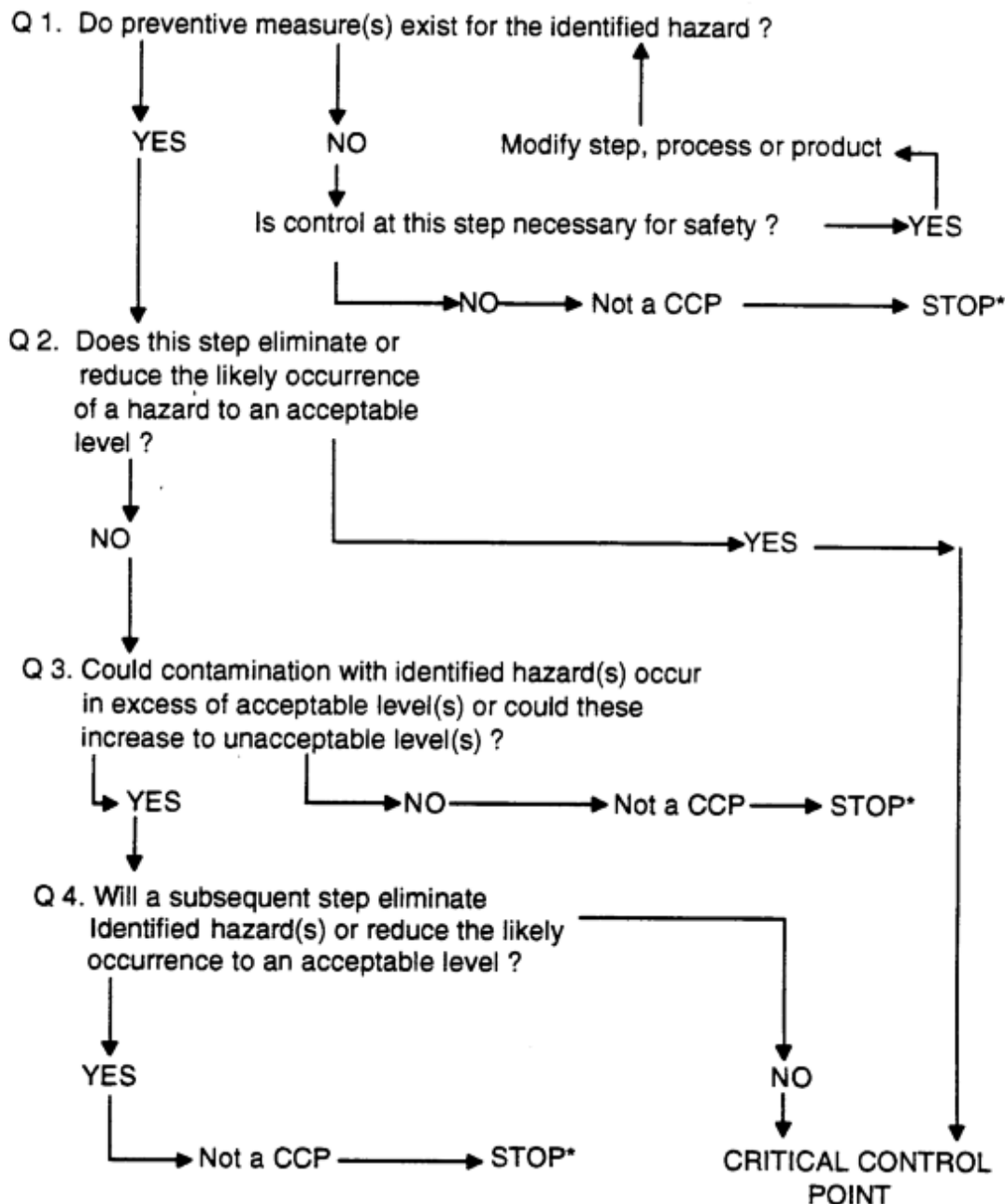

\* PROCEED TO NEXT STEP IN THE DESCRIBED PROCESS

**3) Principle #3: Establish Critical Limits for Preventive Measures Associated with Each Identified Critical Control Point**

This step involves establishing a criterion that must be met for each preventive measure associated with a CCP. Critical limits can be thought of as boundaries of safety for each CCP and may be set for preventive measures such as temperature, time, physical dimensions,  $a_w$ , pH, and available chlorine. Critical limits may be derived from sources such as regulatory standards and guidelines, scientific literature, experimental studies, and consultation with experts.

**Criteria Most Frequently Used for Critical Limits**

Time  
Temperature  
Humidity  
 $a_w$   
pH  
Titratable acidity  
Preservatives  
Salt concentration  
Available chlorine  
Viscosity

a) Critical Limit

A critical limit is defined as a criterion that must be met for each preventive measure associated with a CCP. Each CCP will have one or more preventive measures that must be properly controlled to assure prevention, elimination, or reduction of hazards to acceptable levels. The food establishment is responsible for using competent authorities to validate that the critical limits chosen will control the identified hazard.

b) Target Level

In some cases, variables involved in food preparation may require certain target levels to assure that critical limits are not exceeded. For example, a preventive measure and critical limit may be an internal product temperature of 71°C (160°F) during one stage of a process. The oven temperature, however, may be 71±3°C (160±5°F); thus an oven target temperature would have to be greater than 74°C (165°F) so that no product receives a cook of less than 71°C (160°F).

c) Application Example

An example for Principle #3 is the cooking of beef patties. The process should be designed to eliminate the most heat-resistant vegetative pathogen which could reasonably be expected to be in the product. Criteria may be required for factors such as temperature, time, and meat patty thickness. Technical development of the appropriate critical limits requires accurate information on the probable maximum numbers of these microorganisms in the meat and their heat resistance. The relationship between the CCP and its critical limits for the meat patty example is shown below:

Process Step	CCP	Critical Limits
Cooking	YES	Minimum internal temperature of patty: 68°C/155°F Broiler temperature: _____ °C/ _____ °F  Time; rate of heating/cooling (e.g., conveyer belt speed in): cm/min: _____ ft/min _____ Patty thickness: _____ cm/ _____ in Patty composition: e.g., % Fat, % Filler Oven humidity: _____ %RH

**4) Principle #4: Establish Procedures to Monitor CCPs**

a) Observations and Measurements

Monitoring is a planned sequence of observations or measurements to assess whether a CCP is under control and to produce an accurate record for use in future verification procedures. There are three main purposes for monitoring:

- i) It tracks the system's operation so that a trend toward a loss of control can be recognized and corrective action can be taken to bring the process back into control before a deviation occurs;
- ii) It indicates when loss of control and a deviation have actually occurred, and corrective action must be taken; and
- iii) It provides written documentation for use in verification of the HACCP plan.

Examples of Measurements for Monitoring
---

Visual observations  
 Temperature  
 Time

pH

$a_w$

b) Continuous Monitoring

An unsafe food may result if a process is not properly controlled and a deviation occurs. Because of the potentially serious consequences of a critical defect, monitoring procedures must be effective.

Continuous monitoring is always preferred when feasible and continuous monitoring is possible with many types of physical and chemical methods. For example, the temperature and time for an institutional cook-chill operation can be recorded continuously on temperature recording charts. If the temperature falls below the scheduled temperature or the time is insufficient, as recorded on the chart, the batch must be recorded as a process deviation and reprocessed or discarded.

Instrumentation used by the food establishment for measuring critical limits must be carefully calibrated for accuracy. Records of calibrations must be maintained as a part of the HACCP plan documentation.

c) Monitoring Procedures

When it is not possible to monitor a critical limit on a continuous basis, it is necessary to establish that the monitoring interval will be reliable enough to indicate that the hazard is under control. Statistically designed data collection or sampling systems lend themselves to this purpose. When statistical process control is used, it is important to recognize that violations of critical limits must not occur. For example, when a temperature of 68°C (155°F) or higher is required for product safety, the minimum temperature of the product may be set at a target that is above this temperature to compensate for variation.

Most monitoring procedures for CCPs will need to be done rapidly because the time frame between food preparation and consumption does not allow for lengthy analytical testing. Microbiological testing is seldom effective for monitoring CCPs because of its time-consuming nature. Therefore, physical and chemical measurements are preferred because they may be done rapidly and can indicate whether microbiological control is occurring.

Assignment of responsibility for monitoring is an important consideration for each CCP within the operation. Specific assignments will depend on the number of CCPs, preventive measures, and the complexity of monitoring. The most appropriate employees for such assignments are often directly associated with the operation, such as the person in charge of the food establishment, chefs, and the departmental supervisors.

Individuals monitoring CCPs must be trained in the monitoring technique, completely understand the purpose and importance of monitoring, and be unbiased in monitoring and reporting so that monitoring is accurately recorded.

The designated individuals must have ready access to the CCP being monitored and to the calibrated instrumentation designated in the HACCP plan.

The person responsible for monitoring must also record a food operation or product that does not meet critical limits and assure that immediate corrective action can be taken. All records and documents associated with CCP monitoring must be signed or initialed by the person doing the monitoring.

Random checks may be useful in supplementing the monitoring of certain CCPs. They may be used to check incoming ingredients, serve as a check for compliance where ingredients are recertified as meeting certain standards, and assess factors such as equipment. Random checks are also advisable for monitoring environmental factors such as airborne contamination, and cleaning and sanitizing gloves.

With some foods containing microbiologically sensitive ingredients, there may not be an alternative to microbiological testing. However, it is important to recognize that a sampling frequency which is adequate for reliable detection of low levels of pathogens is seldom possible because of the large number of samples needed. For this reason, microbiological testing has limitations in a HACCP system, but is valuable as a means of establishing and verifying the effectiveness of control at CCPs (such as through challenge tests, random testing, or testing the focuses on isolating the source of a problem).

**5) Principle #5: Establish the Corrective Action to be Taken When Monitoring Shows That a Critical Limit Had Been Exceeded**

a) Purpose of Corrective Action Plan

Although the HACCP system is intended to prevent deviations from occurring, perfection is rarely, if ever, achievable. Thus, there must be a corrective action plan in place to:

- i) Determine the disposition of any food that was produced when a deviation was occurring;
- ii) Correct the cause of the deviation and assure that the critical control point is under control; and
- iii) Maintain records of corrective actions.

b) Aspects of Corrective Action Plan

Because of the variations in CCPs for different food operations and the diversity of possible deviations, specific corrective action plans must be developed for each CCP. The actions must demonstrate that the CCP has been brought under control. Individuals who have a thorough understanding of the operation, product, and HACCP plan must be assigned responsibility for taking corrective action. Corrective action procedures must be documented in the HACCP plan.

Food establishments covered by the Food Code will usually be concerned with food which has a limited shelf-life and distribution. Primary focus for the application of this HACCP principle will be on the correction of the procedure or condition which led to the noncompliance. More frequent monitoring may be temporarily required to assure that the deviation from the established critical limit is not continuing when the operation is resumed.

If a deviation should occur in food operations that are traditionally considered food processing operations, such as cook-chill, curing and smoking, or reduced oxygen packaging, the food establishment must place the product on hold pending completion of appropriate corrective actions and analyses. As appropriate, scientific experts and regulatory agencies must be consulted regarding additional testing or disposition of the product. Identification of deviant lots and corrective actions taken to assure safety of these lots must be noted in the HACCP record. This record must remain on file for a reasonable period after the expiration date of expected shelf life of the product.

**6) Principle #6: Establish Effective Record Keeping Systems That Document the HACCP System**

a) Written HACCP Plan

This principle requires the preparation and maintenance of a written HACCP plan by the food establishment. The plan must detail the hazards of each individual or categorical product covered by the plan. It must clearly identify the CCPs and critical limits for each CCP. CCP monitoring and record keeping procedures must be shown in the establishment's HACCP plan. HACCP plan implementation strategy should be provided as a part of the food establishment's documentation.

b) Record Keeping

The principle requires the maintenance of records generated during the operation of the plan. The record keeping associated with HACCP procedures ultimately makes the system work.

One conclusion of a study of HACCP performed by the U.S. Department of Commerce is that correcting problems without record keeping almost guarantees that problems will recur. The requirement to record events at CCPs on a regular basis assures that preventive monitoring is occurring in a systematic way. Unusual occurrences that are discovered as CCPs are monitored or that otherwise come to light must be corrected and recorded immediately with notation of the corrective action taken.

The level of sophistication of the record keeping necessary for the food establishment is dependent on the complexity of the food preparation operation. A sous vidé process or cook-chill operation for a large institution would require more record keeping than a limited menu cook-serve operation. The simplest effective record keeping system that lends itself well to integration within the existing operation is best.

c) Contents of the Plan and Records

The approved HACCP plan and associated records must be on file at the food establishment. Generally, the following are examples of documents that can be included in the total HACCP system:

- i) Listing of the HACCP team and assigned responsibilities;
- ii) Description of the product and its intended use;
- iii) Flow diagram food preparation indicating CCPs;
- iv) Hazards associated with each CCP and preventive measures;
- v) Critical limits;
- vi) Monitoring system;
- vii) Corrective action plans for deviations from critical limits;
- viii) Record keeping procedures; and
- ix) Procedures for verification of HACCP system.

d) Format for HACCP information

In addition to listing the HACCP team, product description and uses, and providing a flow diagram, other information in the HACCP plan can be tabulated as follows:

Process Step	CCP	Chemical Physical Biological Hazards	Critical Limit	Monitoring Procedures Frequency Person(s) Responsible	Corrective Action(s) Person(s) Responsible	HACCP Records	Verification Procedures/ Person(s) Responsible
--------------	-----	---	-------------------	---	---	------------------	---

The following chart is an example of a HACCP plan documentation for a product cooling step in a retail level food establishment.

Process Step	Cooling
CCP	Critical Control Point #8
Criteria or Critical Limit	Cool Foods Rapidly in Small Quantities to 5°C (41°F)
Establish Monitoring	Department Personnel Break Down Food into Small Quantities and Monitor the Cooling Process

Corrective/Preventive Action	Modify Cooling Procedures/Discard
HACCP Records	Deli Cooking/Cooling Log
HACCP System Verification	Deli Safety Audit by Store Manager

e) Examples of Records Obtained During the Operation of the Plan:

i) Ingredients

- Supplier certification documenting compliance with establishment's specifications.
- Establishment audit records verifying supplier compliance.
- Storage temperature record for temperature-sensitive ingredients.
- Storage time records of limited shelf-life ingredients.

ii) Preparation

Records from all monitored CCPs.

- Records verifying the continued adequacy of the food preparation procedures.

iii) Packaging

- Records indicating compliance with specifications of packaging materials.
- Records indicating compliance with sealing specifications.

iv) Finished product

- Sufficient data and records to establish the efficacy of barriers in maintaining product safety.
- Sufficient data and records establishing the safe shelf-life of the product; if age of product can affect safety.
- Documentation of the adequacy of the HACCP procedures from an authority knowledgeable of the hazards involved and necessary controls.

v) Storage and distribution

- Temperature records.
- Records showing no product shipped after shelf life date on temperature-sensitive products.

vi) Deviation and corrective action

- Validation records and modification to the HACCP plan indicating approved revisions and changes in ingredients, formulations, preparation, packaging, and distribution control, as needed.
- vii) Employee training
- Records indicating that food employees responsible for implementation of the HACCP plan understand the hazards, controls, and procedures. Refer to the discussion regarding Training and Knowledge under Principle #7.

**7) Principle #7: Establish Procedures to Verify that the HACCP System is Working**

- a) Establishing Verification Procedures
- i) The first phase of the process is the scientific or technical verification that critical limits at CCPs are satisfactory. This can be complex and may require intensive involvement of highly skilled professionals from a variety of disciplines capable of doing focused studies and analyses. A review of the critical limits is necessary to verify that the limits are adequate to control the hazards that are likely to occur.
  - ii) The second phase of verification assures that the facility's HACCP plan is functioning effectively. A functioning HACCP system requires little end-product sampling, since appropriate safeguards are built in early in the food preparation. Therefore, rather than relying on end-product sampling, food establishments must rely on frequent reviews of their HACCP plan, verification that the HACCP plan is being correctly followed, review of CCP records, and determinations that appropriate risk management decisions and product dispositions are made when preparation deviations occur.
  - iii) The third phase consists of documented periodic revalidations, independent of audits or other verification procedures, that must be performed to assure the accuracy of the HACCP plan. Revalidations are performed to assure the accuracy of the HACCP plan. Revalidations are performed by a HACCP team on a regular basis and/or whenever significant product, preparation, or packaging changes require modification of the HACCP plan. The revalidation includes a documented on-site review and verification of all flow diagrams and CCPs in the HACCP plan. The HACCP team modifies the HACCP plan as necessary.

- iv) The fourth phase of verification deals with the regulatory agency's responsibility and actions to assure that the establishment's HACCP system is functioning satisfactorily.
- b) The following are some examples of HACCP plan verification activities which should be used as a part of a HACCP program:
- i) Verification procedures may include:
    - Establishment of appropriate verification inspection schedules;
    - Review of the HACCP plan;
    - Review of CCP records;
    - Review of deviations and their resolution, including the disposition of food;
    - Visual inspections of operations to observe if CCPs are under control;
    - Random sample collection and analysis;
    - Review of critical limits to verify that they are adequate to control hazards;
    - Review of written record of verification inspections which certifies compliance with the HACCP plan or deviations from the plan and the corrective actions taken;
    - Validation of HACCP plan, including on-site review and verification of flow diagrams and CCP; and
    - Review of modifications of the HACCP plan.
  - ii) Verification inspections should be conducted:
    - Routinely or on an unannounced basis, to assure that selected CCPs are under control;
    - When it is determined that intensive coverage of a specific food is needed because of new information concerning food safety;
    - When foods prepared at the establishment have been implicated as a vehicle of foodborne disease;
    - When requested on a consultative basis and resources allow accommodating the request;
    - When established criteria have not been met; and
    - To verify that changes have been implemented correctly after a HACCP plan has been modified.

- iii) Verification reports should include information about:
- Existence of a HACCP plan and the person(s) responsible for administering and updating the HACCP plan;
  - The status of records associated with CCP monitoring;
  - Direct monitoring data of the CCP while in operation; Certification that monitoring equipment is properly calibrated and in working order;
  - Deviations and corrective actions;
  - Any samples analyzed to verify that CCPs are under control. Analyses may involve physical, chemical, microbiological, or organoleptic methods;
  - Modifications to the HACCP plan; and
  - Training and knowledge of individuals responsible for monitoring CCPs.

c) Training and Knowledge

i) Focus and Objective

Training and knowledge are very important in making HACCP successful in any food establishment. HACCP works best when it is integrated into each employee's normal duties rather than added as something extra.

The depth and breadth of training will depend on the particular employee's responsibilities within the establishment. Management or supervisory individuals will need a deeper understanding of the HACCP process because they are responsible for proper plan implementation and routine monitoring of CCPs such as product cooking temperatures and cooling times. The training plan should be specific to the establishment's operation rather than attempt to develop HACCP expertise for broad application.

The food employee's training should provide an overview of HACCP's prevention philosophy while focusing on the specifics of the employee's normal functions. The CCPs such as proper handwashing and use of utensils or gloves for working with ready-to-eat food should be stressed. The use of recipes of Standard Operating Procedures (SOPs) which include the critical limits of cooking times and temperatures, with a final cooking time and temperature measurement step, should be included.

For all employees, the fundamental training goal should be to make them proficient in the specific tasks which the HACCP plan requires them to perform. This includes the development of a level of competency in their decision-making about the implementation of proper corrective actions when monitoring reveals violation of the critical limit. The

training should also include the proper completion and maintenance of any records specified in the establishment's plan.

ii) Reinforcement

Training reinforcement is also needed for continued motivation of the food establishment employees. Some examples might include:

- A HACCP video training program such as the Pennsylvania Department of Environmental Regulation's Foodborne Illness: It's Your Business;
- Changing reminders about HACCP critical limits such as "HANDWASHING PAYS BIG DIVIDENDS" printed on employee's time cards or checks; and
- Work station reminders such as pictorials on how and when to take food temperatures.

Every time there is a change in a product or food operation within the establishment, the HACCP training needs should be evaluated. For example, when a food establishment substitutes a frozen seafood product for a fresh one, proper thawing critical limits should be taught and then monitored for implementation. The employees should be made sensitive to how the changes will affect food safety.

The HACCP plan should include a feedback loop for employees to suggest what additional training is needed. All employees should be made a part of the continuous food safety improvement cycle because the old statement is very true, "The customer's health is in their hands". This helps maintain their active awareness and involvement in the importance of each job to the safety of the food provided by their establishment.

### **3. Summary**

HACCP is a systematic approach to food safety which will dramatically improve the level of food safety. The NACMCF has developed the seven HACCP principles discussed within this Appendix. The FDA recommends the implementation of a HACCP system throughout the food industry using these NACMCF recommendations.

An effective national food safety program from food production to consumer is enhanced by the implementation of HACCP. The statistics from foodborne surveillance reveal that retail level food establishments can have a significant impact on the health of consumers.

Implementation of HACCP programs by the establishments will profoundly enhance their role in the protection of public health beyond the traditional emphasis on facility and equipment design and maintenance and adherence to the principles of sanitation, good manufacturing, and food preparation practices. The education and training of all personnel are critical to the success and effectiveness of any HACCP program. The Food Code stresses the application to HACCP principles and the knowledge and responsibilities of establishment management and employees.

Specific HACCP plans for the products prepared and sold by the retail food establishment should be developed and implemented for optimal food safety management. HACCP systems are recommended for optimal food safety management. HACCP systems are recommended for use as a tool for regulatory inspections. The regulatory official should incorporate procedures in the inspection process that assure record reviews and active monitoring.

Because the retail food establishment industry is composed of large, small, chain, and independent establishments, the level of food safety expertise varies widely and is not necessarily linked to size or affiliation. Regardless of the size and sophistication of the establishment, a HACCP plan for safe food preparation and sales needs to be designed, implemented, and verified.

Studies have shown that a significant level of illness and mortality from foodborne disease in institutional feeding operations such as hospitals, nursing homes, and prisons is related to preventable causes. For populations that may be more vulnerable to foodborne disease, FDA and the NACMCF recommend that HACCP systems be immediately implemented by establishments and institutions preparing foods for these susceptible individuals.

Food processing operations at retail food establishments such as reduced oxygen packaging and curing and smoking under the Food Code are required to develop and implement a HACCP plan for that part of the operation. Additionally, any establishment seeking a variance from the requirements of the Code must submit a HACCP plan. The HACCP Appendix can serve to guide these establishments in this process.

Food establishments have the primary responsibility for food safety. The development and implementation of HACCP programs is a reliable and responsible step to help assure the safety of food offered for consumption.

#### **4. Acknowledgments**

Much of this HACCP Appendix material is adapted from National Advisory Committee on Microbiological Criteria for Foods, Hazard Analysis and Critical Control Point System, adopted March 20, 1992.

Some of the charts were provided courtesy of “Overview of Biological, Chemical, and Physical Hazards” in “HACCP Principles and Applications”, Merle Pierson and Donald A. Corlett, Jr. (Eds.), 1992 p 8-28. Chapman and Hall, New York.

#### **5. Bibliography**

- Bean, N.H. and P.M. Griffen 1990. Foodborne disease outbreaks in the United States, 1973-87. *J. Food Prot.* 53(9):804-817.
- Bjerklie, S., 1992. HACCP in your plant: What HACCP is, what it isn't and how your operations will be affected. *Meat and Poultry* 38(2):14-22.
- Bryan, F.L., 1990. Hazard analysis critical control point (HACCP) systems for retail food and restaurant operations. *J. Food Prot.* 53(11):978-983.

- Bryan, F.L., 1988. Risks associated with vehicles of foodborne pathogens and toxins. *J. Food Prot.* 51(6):498-508.
- Bryan, F.L., 1988. Risks of practices, procedures and processes that lead to outbreaks of foodborne diseases. *J. Food Prot.* 51(8):663-673.
- Bryan, F.L., P. Teufel, S. Riaz, S. Roohi, F. Quadar and Z. Malik, 1992. Hazards and critical control points of vending operations at a railway station and a bus station in Pakistan. *J. Food Technol.* 55(7):534-541.
- Bryan, F.L., C.A. Bartelson, C.O. Cook, P.Fisher, J.J. Guzewich, B.J. Humm, R.C. Swanson, and E.C.D. Todd, 1991. Procedures to Implement the Hazard Analysis Critical Control Point System. Int. Assoc. of Milk, Food, Environ. Sanitarians, Ames, IA, 72 pp.
- Buchanan, R.L., 1990. HACCP: A re-emerging approach to food safety. *Trends in Food Science & Technology*, November 1990, Elsevier Science Publishers, Inc.
- Corlett, D.A., Jr., 1989. Refrigerated foods and use of hazard analysis and critical control point principles. *Food Technol.* 43(2):91-94.
- Corlett, D.A. Jr., 1991. Regulatory verification of industrial HACCP systems. *Food Technol.* 45(5):144-146.
- Cox, L.J., 1989. A perspective on listeriosis. *Food Technol.* 45(12):52-59.
- Curiale, M.S., 1991. Shelf-life evaluation analysis. *Dairy, Food Environ. Sanit.* 11(7):364-369.
- Educational Foundation of the National Restaurant Association, 1993. HACCP Reference Book. Educational Foundation, Chicago, IL.
- Food Marketing Institute., 1989. *Food handler's pocket guide for food safety and quality*. Washington, D.C.
- Food Marketing Institute., 1989. *A program to ensure food safety in the supermarket--the hazard analysis critical control point system*. Washington, D.C.
- Foster, E.M., 1989. A half-century of food microbiology. *Food Technol.* 43(9):208-215.
- Guzewich, J.J., 1987. *Practical Procedures for Using the hazard Analysis Critical Control Point (HACCP) Approach in Food Service Establishments by Industry and Regulatory Agencies*. Lewis Publishers, Inc., Chelsea, MI.
- International Association of Milk, Food and Environmental Sanitarians, Inc., 1991 *Procedures to implement the hazard analysis critical control point system*. Des Moines, IA.
- International Commission on Microbiological Specifications for Foods, 1986. *Microorganisms in Foods 2. Sampling for microbiological analysis: Principles and specific applications*. 2nd ed. University of Toronto Press, Toronto.
- International Commission on Microbiological Specifications for Foods, 1989. *Microorganisms in Foods 4. Application of hazard analysis and critical control point (HACCP) system to ensure microbiological safety and quality*. Blackwell Scientific Publications, Boston.
- Kemp, S., 1991. Start a quality improvement program. North Carolina State University, Sea Grant College Program. Raleigh, NC. *Seafood Current*, 5(1).

- Lee, J.S., with K.S. Hilderbrand Jr., 1992. *Hazard analysis & critical control point applications to the seafood industry*. ORESU-H-92-001. Oregon Sea Grant, Oregon State University. Corvallis, OR.
- Lydecker, T., 1991. How self-inspection flies: HACCP systems in airline catering companies. *Food Service Director*. 15:87.
- Martin, P., 1991. Hazard control. *Restaurant Business*, 1:256.
- McIntyre, C.R. 1991. Hazard analysis critical control point (HACCP) identification. *Dairy, Food and Environ. Sanit.* 11(7):357-358.
- National Advisory Committee on Microbiological Criteria for Foods, 1992. Hazard analysis and critical control point system. *Int. J. Food Microbial.* 16:1-23.
- National Fisheries Institute, 1991. *Seafood industry, hazard analysis critical control point, HACCP, training manual*. Arlington, VA.
- National Food Processors Association, 1992. HACCP and total quality management--winning concept for the 90's: A review. *J. Food Prot.* 55:459-462.
- New England Fisheries Development Association, 1991. *HACCP manual for processors*. 309 World Trade Center, Boston, MA 02210-2001.
- Pierson, M.D. and D.A. Corlett, Jr., 1992, HACCP Principles and Applications, Van Nostrand Reinhold, New York. 212 pp.
- Pisciella, J.A., 1991. *A handbook for the practical application of the hazard analysis critical control point approach to food service establishment inspection*. Central Atlantic States Association of Food and Drug Officials, c/o William Kinder, Pennsylvania Department of Agriculture, PO Box 300, Creamery, PA 19430.
- Pisciella, J.A., 1991. Overcoming the barriers to HACCP in restaurants. *Food Prot. Inside Rpt.* July-August:2A.
- Price, R.J. (Ed.), 1985. *Seafood retailing manual*, 3rd ed. University of California, Sea Grant Extension Program, Davis, CA.
- Price, R.J., 1990. *Retail seafood cross-contamination*. UCSGEP 90-6. University of California, Food Science & Technology Department. Davis, CA 95616.
- Price, R.J., 1990. Retail seafood temperature control. UCSGEP 90-5. University of California, Food Science & Technology Department. Davis, CA 95616.
- Price, R.J., P.D. Tom, and K.E. Stevenson, 1993. Ensuring food safety--The HACCP way. University of California, Food Science & Technology Department, Davis, CA 95616.
- Rhodes, M.E., 1991. Educating professionals and consumers about extended-shelf-life refrigerated foods. *Food Technol.* 47(4):182-183.
- Snyder, O.P., 1991. HACCP in the retail food industry. *Dairy, Food Environ. Sanit.* 11(2):73-81.
- Stevenson, K.E., 1990. Implementing HACCP in the food industry. *Food Technol.* 42(5):179-180.

Sumner, S.S., et al., 1992. Food Safety/Food Sanitation Workshop, *Introduction to HACCP Procedures-Final Report* (special project number 91-EFSQ-4021). Nebraska Cooperative Extension. University of Nebraska, Lincoln, NE 68583-0919.

## **6. Other Sources of HACCP Information**

FDA Prime Connection. A Free On-Line HACCP Technical Database. For registration information, contact FDA PRIME CONNECTION, 200 C Street SW-HFS-625, Washington, D.C. 20204-0001 or call (202) 205-8140.

PA Department of Environmental Resources, 1992. *Foodborne Illness: It's your business* (HACCP video). Division of Food Protection, Food Facilities Section, Harrisburg, PA.

# Two Typical Flow Diagrams

**Flow Chart 1**

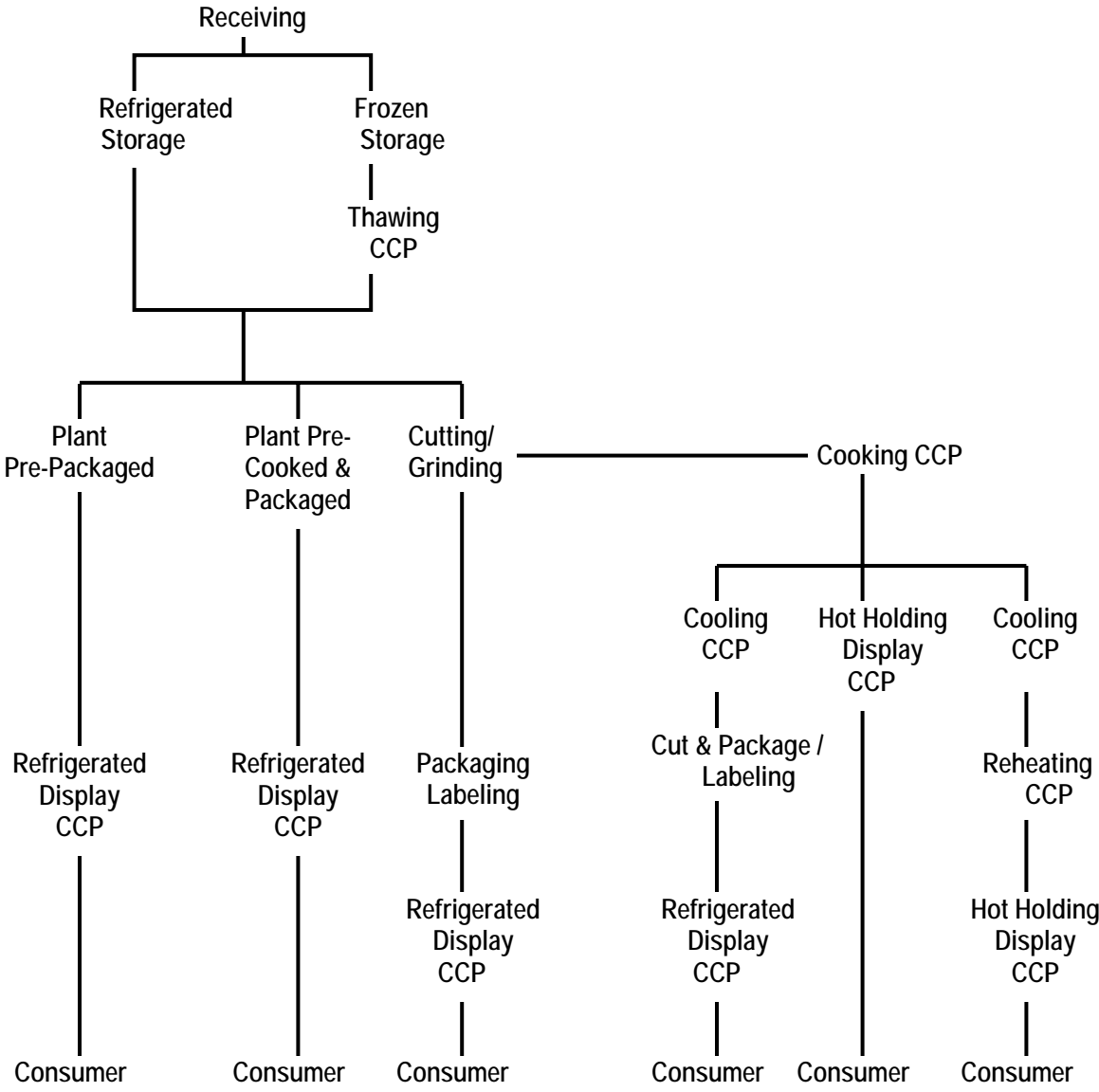

## Flow Chart 2

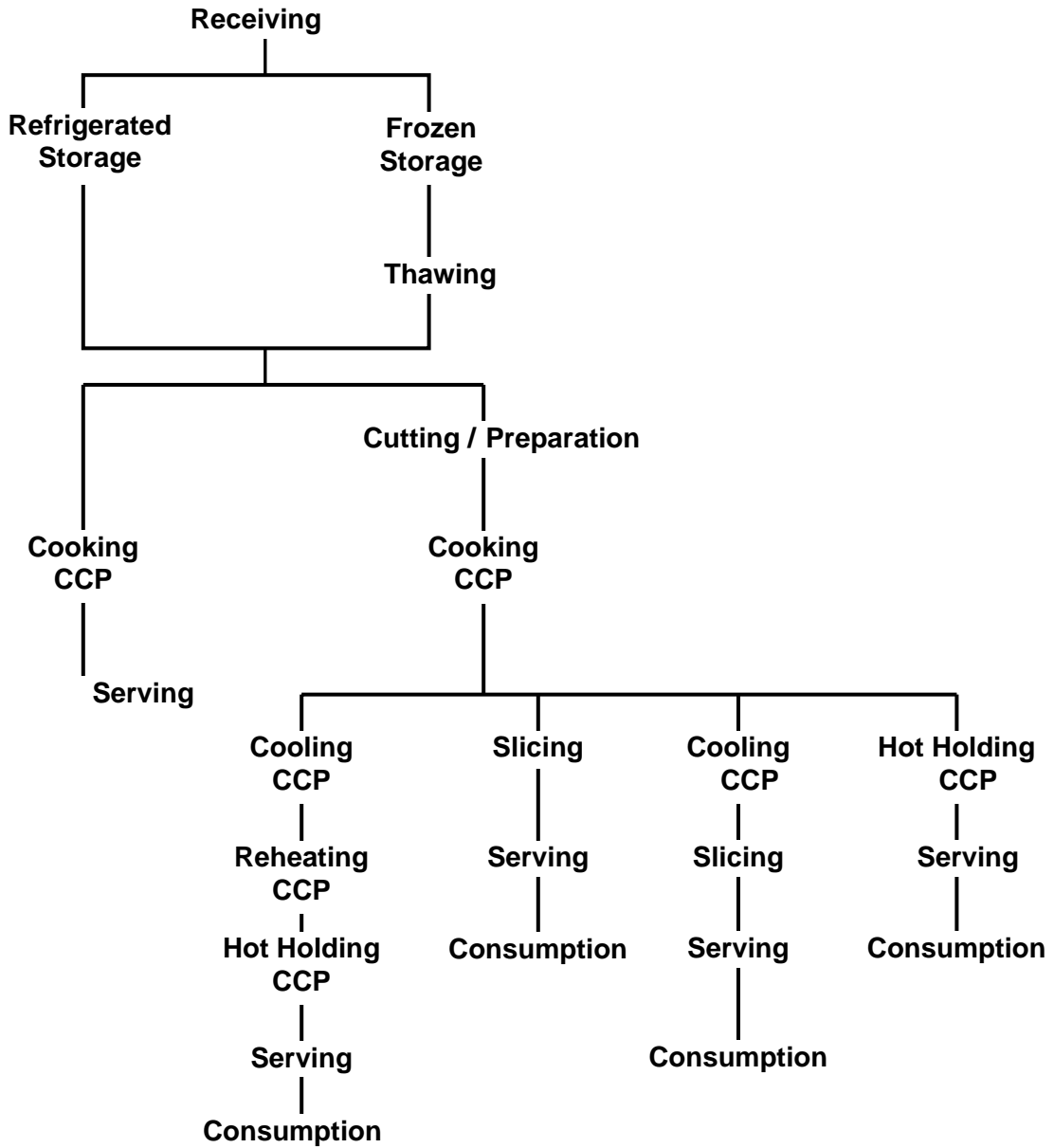

## ***Appendix I - RETAIL FOOD STORE SANITATION ACT***

25-4-1301. Legislative declaration. The general assembly hereby declares that the sanitary protection of bulk foods and the sanitary maintenance of equipment used to display and dispense bulk foods are matters of statewide concern and are affected with a public interest and that the provisions of this part 13 are enacted in the exercise of the police powers of this state for the purpose of protecting the health, peace, safety, and general welfare of the people of this state.

25-4-1302. Definitions. As used in this part 13, unless the context otherwise requires:

(1) “Bulk foods” means unpackaged or unwrapped foods, either processed or unprocessed, in aggregate containers from which quantities desired by the consumer are withdrawn. “Bulk foods” does not include fresh fruits, fresh vegetables, nuts in the shell, salad bar, bulk pet foods, potentially hazardous foods, and bulk nonfood items.

(2) “Department” means the department of health.

(3) “Display area” means a location including physical facilities and equipment, where bulk foods are offered for customer self-service.

(4) “Potentially hazardous foods” includes any food that consists in whole or in part, of milk or milk products, eggs, meat, poultry, fish, shellfish, edible crustacea, or other food products or ingredients, including synthetic ingredients, in a form capable of supporting rapid and progressive growth of infectious or toxigenic microorganisms. This term does not include refrigerated, clean, whole, uncracked, odor-free shell eggs.

(5) “Product module” means a food-contact container (multiuse or single-service) designed for customer self-service of bulk foods by either direct or indirect means.

(6) “Servicing area” means a designated location equipped for cleaning, sanitizing drying, or refilling product modules or for preparing bulk foods.

25-4-1303. Labeling - product modules - take-home containers. (1) product modules shall be labeled with either:

(a) The manufacturer's or processor's bulk food container labeling plainly in view; or

(b) A counter card, a counter sign, or any other appropriate device bearing prominently and conspicuously the common name of the product, a list of ingredients in their proper

order of predominance, and a declaration of artificial color or flavor and chemical preservatives if contained in the product.

(2) any unpack aged bulk food need not comply with the labeling requirements of this section if the unpackaged bulk food is manufactured on the premises of a store or manufactured by the same store at the different location and if the manufactured bulk food is offered for retail sale on the store's premises and if there are no state requirements.

(3) Labels or marking pens shall be available to customers to identify their take-home containers with the common name of the product unless the product is readily identifiable on sight.

25-4-1304. Bulk food protection. (1) Bulk foods and product modules shall be protected. from contamination during , display, customer self-service, refilling, and storage.

(2) Containers of bulk pet foods and bulk nonfood items shall be separated from product modules by a barrier or open space.

(3) Bulk foods returned to stores by customers shall not be offered for resale.

(4) Only containers provided by stores in their display areas shall be filled with bulk foods; except that any customer may fill or refill his own containers with vended or dispensed water; however, the risk that the customer's own container is unsafe, unpure, contaminated, or in a non sterile condition when it is filled or refilled by the customer, shall be borne solely by the customer, and, except for warranties, no liability shall attach thereto to the manufacturer, seller, or dispenser of such container.

25-4-1305. Bulk food display. (1) Bulk foods shall be dispensed only from product modules which are protected by close-fitting, individual covers. If any product module is to be opened by customers, the cover shall be self-closing and shall remain close when not in use.

(2) Customer access to bulk foods in product modules shall be limited and controlled to avoid the introduction of contaminants. All product modules shall have an access height of thirty inches or more above the floor and a depth of eighteen inches or less.

(3) Potentially hazardous foods shall not be made available for customer self-service.

25-4-1306. Dispensing utensils. (1) Manual handling of bulk foods by customers during dispensing shall by discouraged. Mechanical dispensing devices shall be used, including

gravity dispensers, pumps, extruders, and augers. Manual dispensing utensils shall also be used, including tongs, scoops, ladles, and spatulas.

(2) If the dispensing devices and utensils listed in subsection (1) of this section do not discourage manual customer handling of bulk foods, such bulk foods must be wrapped or sacked prior to display.

(3) Manual dispensing utensils shall be protected against becoming contaminated and serving as vehicles for introducing contamination into bulk foods. A tether of easily cleanable material shall be attached to such a utensil and shall be of such length that the utensil cannot contact the floor. A sleeve or protective housing attached or adjacent to the display unit shall be available for storing a utensil when not in use.

(4) Ladles and spatulas shall be stored in bulk foods with handles extending to the outside of product modules. Handles shall not prevent lids from being self-closing.

25-4-1307. Materials. Product modules and utensils shall be constructed of safe materials and shall be corrosion resistant, nonabsorbent, smooth, easily cleanable, and durable under conditions of normal use. Wood shall not be used as a food-contact surface.

25-4-1308. Food-contact surfaces. Product modules, lids, dispensing units, and utensils shall be designed and fabricated to meet the requirements for food-contact surfaces, as provided in section 25-4-1307.

25-4-1309. Non-food-contact surfaces. Surfaces of product module display units, tethers, and display equipment which are not intended for food contact but which are exposed to splash, food debris, or other soiling shall be designed and fabricated to be smooth, cleanable, durable under conditions of normal use, and free of unnecessary ledges, projections, and crevices. The materials for non-food-contact surfaces shall be nonabsorbent or made nonabsorbent by being finished and sealed with a cleanable coating.

25-4-1310. Accessibility. Individual product modules shall be designed to be easily removable from a display unit for servicing unless the product modules are so designed and fabricated that they can be effectively cleaned and sanitized when necessary through a manual in-place cleaning procedure that will not contaminate or otherwise adversely affect bulk foods or equipment in any adjoining display areas.

25-4-1311. Equipment sanitization. (1) Tongs, scoops, ladles, spatulas, and other appropriate utensils and tethers used by customers shall be cleaned and sanitized at least daily or at more frequent intervals based on the type of bulk food and the amount of food particle accumulation of soiling.

(2) When soiled, product modules, lids, and other equipment shall be cleaned and sanitized prior to restocking or at intervals of a schedule based on the type of bulk food and the amount of food particle accumulation.

(3) Food-contact surfaces shall be cleaned and sanitized immediately if contamination is observed or suspected.

(4) Facilities and equipment shall be available, either in a servicing area or in place, to provide for the proper cleaning and sanitizing of all food-contact surfaces, including product modules, lids, and dispensing utensils.

(5) Take-home containers, including but not limited to bags, cups, and lids, which are provided in a display area for customer use shall be stored and dispensed in a sanitary manner.

25-4-1312. Violation - Penalty. Any retail food store owner violating any of the provisions of this part 13 is guilty of a misdemeanor and, upon conviction thereof, shall be punished by a fine of not more than five hundred dollars, or by imprisonment in the county jail for not more than ninety days, or by both such fine and imprisonment. It is the duty of the district attorneys of the several districts of this state to prosecute for violations of this part 13 as for other crimes and misdemeanors.

25-4-1313. Rules and regulations. The department has the power to promulgate rules and regulations for the implementation of this part 13.

25-4-1314. Limitation. The provisions of this part 13 shall be expressly limited to retail food store outlets.

## ***APPENDIX J - Equipment Investigation Report***

Section 4-101 of the Colorado Retail Food Establishment Rules and Regulation specify all equipment, utensils and single-service articles shall be fabricated with safe materials; be of commercial design, that is certified or classified for sanitation by an American National Standards Institute (ANSI) accredited certification program or a design approved by the Department.

If a retail food establishment intends to have any equipment, utensils and single-service articles approved by the Department, the approval will be based upon submission of the following information to be provided to the local health agency and/or the Colorado Department of Public Health and Environment for evaluation.

**COLORADO DEPARTMENT OF PUBLIC HEALTH & ENVIRONMENT  
4300 CHERRY CREEK DRIVE SOUTH  
DENVER, CO 80246-1530**

<b>EQUIPMENT INVESTIGATION REPORT</b>	
1. LOCATION (STATE AND COUNTY)	
2. TYPE OF PROGRAM (CHECK ONE)	3. RECOMMENDATION
<input type="checkbox"/> FOOD SERVICE ESTABLISHMENT <input type="checkbox"/> FOOD WAREHOUSE AND MANUFACTURER <input type="checkbox"/> RETAIL MARKET	<input type="checkbox"/> ACCEPT <input type="checkbox"/> REJECT
4. PREPARED BY	
NAME _____	
TITLE _____	
AGENCY _____	
SIGNATURE _____	DATE _____
5. NAME / TITLE / ORGANIZATION REQUESTING INVESTIGATION	6. DATE OF REQUEST
7. NAME AND ADDRESS OF MANUFACTURER	8. DATE OF INVESTIGATION
9. NAME AND TITLE OF CONTACT	
<b>EQUIPMENT INFORMATION</b>	
10. TRADE NAME	11. MODEL NUMBER
12. DESCRIPTION OF EQUIPMENT (CHECK APPROPRIATE LINE AND DESCRIBE)	
<input type="checkbox"/> PROTOTYPE <input type="checkbox"/> PRODUCTION <input type="checkbox"/> IN USE <input type="checkbox"/> OTHER	
13. SPECIFIC USE OF EQUIPMENT	
14. FOOD-CONTACT SURFACE MATERIAL TYPE (CHECK APPROPRIATE LINE AND DESCRIBE)	
<input type="checkbox"/> METAL _____	<input type="checkbox"/> PAINT _____
<input type="checkbox"/> RUBBER _____	<input type="checkbox"/> PLASTIC _____
15. PLEASE ATTACH A SPECIFICATION SHEET OR A BLUE PRINT DRAWING OF EQUIPMENT	

16. RESULTS OF INVESTIGATION

17. ACTION TAKEN

18. COMMENTS

